

Smart Wasp Pallet wrapping Machine Manual

(please read carefully before using it)

Model:X300



Preface

Thank you for your purchase the equipment of Suzhou Auto-well Industrial Automation Co.ltd.

pallet wrapping machine X300 is suitable for packaging of bulk cargo container transport and parts of the tray is extensively used in foreign trade and exports, the bottle cans, paper, hardware and electric appliance, plastic chemical industry, building materials, agricultural products, food and beverage, glass, animal husbandry, pharmaceutical and other industries.

X300 is beautiful in appearance, easy to operate, simple maintenance, high energy production to meet the production requirements of your company.

In order to help your company to be faster and better use the advanced features of our products, we will provide you with very detailed technical information.

We are very willing to answer your questions if you have any confusion about our products.

Wishes you (your company) the business good

Before using the machine, please read this manual carefully
If you have any technical changes without notice

Contents

1	the equipment delivery list.....	5
2	equipment installation.....	5
	1 .Preparation before installation.....	5
	1.1 area preparation.....	6
	1.2 ground confirmation.....	6
	1.3 electrical confirmations	6
	1.4 equipment、 tools and personnel requirements.....	7
	1.5 equipment loading and unloading and transporting.....	7
	1.6 General hardware fastening torque reference.....	7
	2. Installments.....	8
	2.1 column installments	8
	2.2 film carriage installation.....	12
	2.3 cutting film system installation.....	错误！未定义书签。
	2.4 alarm lamp installation.....	错误！未定义书签。
	2.5 film carriage power connection.....	14
	2.6 door installation.....	20
	2.7. tidy the wire	22
	2.8. top pressure deivce installation	22
	3. test equipment.....	22
	3.1 matters needing attention.....	25
	3.2 test preparation.....	26
	3.3 equipment pretest.....	26
3	device parameters.....	29
4	Equipment introduction.....	30
	1. overview of devices and Applications.....	30
	2 . introduction of the whole machine.....	32
	3. column.....	34
	3.1 Lifting and moving group.....	35
	3.2 Lifting body.....	37
	4. chass.....	38
	5. Film carriage.....	40
	6. Electromagnet obstruct device.....	44
5	Human computer interface.....	48
	1.Starting page.....	48
	2. automatic page.....	49
	3. manual page.....	51
	4. parameter settings page.....	52
	4.1system parameter page.....	54
	4.5 I/O monitor page.....	56
	5.help page.....	57
6	Operating procedures.....	58

1.starting up.....	58
2.Mounting film.....	58
2.1 install membrane preparation.....	58
2.2 install film.....	59
7 Common breakdown and elimination.....	60
1. indicator light doesn't work.....	60
2.turntable doesn't work.....	60
3. lifting device doesn't work.....	60
4. stretch film is pulled off.....	61
5. Electromagnet obstruct device doesn't work.....	61
6. cutting film system doesn't work.....	61
8 Equipment safety precautions.....	61
9 Circuit diagram.....	62
10 Machine safety -----	69
11 care and maintenance.....	64
1. preparation before maintenance.....	64
2. maintenance points.....	64
3.key maintenance instructions.....	65
Attached: Equipment Checklist.....	68
1 daily check list.....	70

1 the equipment delivery list

Please note: after the opening of the control list items complete shipment confirmation

Serial no.	name	quantity	remarks
1	Column	1	
2	Chassis	1	
3	Film Carriage	1	
4	Cutting film	1	
5	Cutting film fixed block	2	
6	Alarm lamp	1	
7	Six angle wrench	1	
8	Door key	1	
9	instructions	1	
10	Remote control	1	
11	M10*20Pan head bolts	2	For Column installation
12	M10*20Inner six angle bolt / elastic / flat pad	2	For Column installation
13	M6*20Inner six angle bolt / elastic / flat pad	4	For Alarm lamp installation
14	Front door panel	3	
15	Back door panel	3	The back door with lock plate
16	The side plate (with lock, lock)	3	
17	M8*25 Bolt	6	For cutting film system installation
18	M10*70 Bolt (all teeth) / nut	1	For Film carriage installation
19	M10*50Bolt / elastic / flat pad	2	For Film carriage installation
20	Tie	15	Connecting line

2 equipment installation

1 .Preparation before installation

Please read the entire installation section before you start, then step by step according to the instructions for installation.



Note:

A.complete each step and then proceed to the next step.

B.if the problems encountered in the installation process, please see the "troubleshooting", to help find it and solve problems.

C.this equipment in the design process includes many security protection measures, such as using the method of correctly is very safe when operation. If there is no operation of equipment in accordance with the safety and the right way, it is likely to be the operator or other personnel near will cause potential safety hazard. During normal operation, attention should be paid to comply with all safety signs. Before the installation is complete, please don't put through power supply.

1.1 area preparation

This equipment installation is convenient, can be installed on the surface of the earth, can also be used in a pit and hand forklift/forklift truck product, at the same time space need to meet the following requirements:

A.The distance from film carriage lateral to the wall is not less than 600 mm;

B.the distance from the back of columns to the wall is not less than 300 mm;

1.2 ground confirmation

The ground must be able to withstand the equipment weight to add on the equipment the maximum load capacity and the impulse capacity, namely request:

Ground supporting capacity \geq (680KG+ product weight) by 1.5 time.



watch out!

Equipment around the ground must be flat, otherwise it may lead to wheel load rotating difficult and sound bigger and may result in equipment damage.

1.3 electrical confirmations

The system needs a special-purpose single-phase earth power source:

220VAC; 10A; 50/60Hz,1PH

Attention: The concrete electrical request, please refer the equipment marking label or the electrical blueprint.



watch out!

- A. using extension cord or any change may cause the circuit damage or affect the equipment performance, and can lead to he maintenance expiration.
- B. to avoid equipment damage, please check voltage of electrical drawings before boot device

1.4 equipment、 tools and personnel requirements

- A.a set of JSK pallet wrapping machine
- B.a set of tools (come with machine), a set of forklift trucks
- C. mechanical/electrical technician 1 or 2, the use of personnell

1.5 equipment loading and unloading and transporting

- A.equipment main component
Equipment mainly includes chassis, turntable, column, film carriage , cutting system and electromagnet blocking device
- B. loading and unloading
Small parts, such as film carriage and so on removed from the car, in case of falling damage when unloading bulk
Main body (chassis and column) through using forklift to unload it and transport to the installation place

1.6 General hardware fastening torque reference

Metric fastener torque chart		
Fastener size	Performance level	torque (Nm)
6mm	8.8	14
8mm	8.8	24
10mm	8.8	54
12mm	10.9	102

2. Installments

Note: pictures and illustrations are for reference only, actual equipment may be different.

A.using the forklift to move the equipment to the installment area and remove the outer packing

B. takes out the stochastic tool, counting equipment is complete and Placed in order dismantle lifting body and move it to the bottom of columns.

2.1 column installments

A. raises up the column (pay attention to security, when installing column)

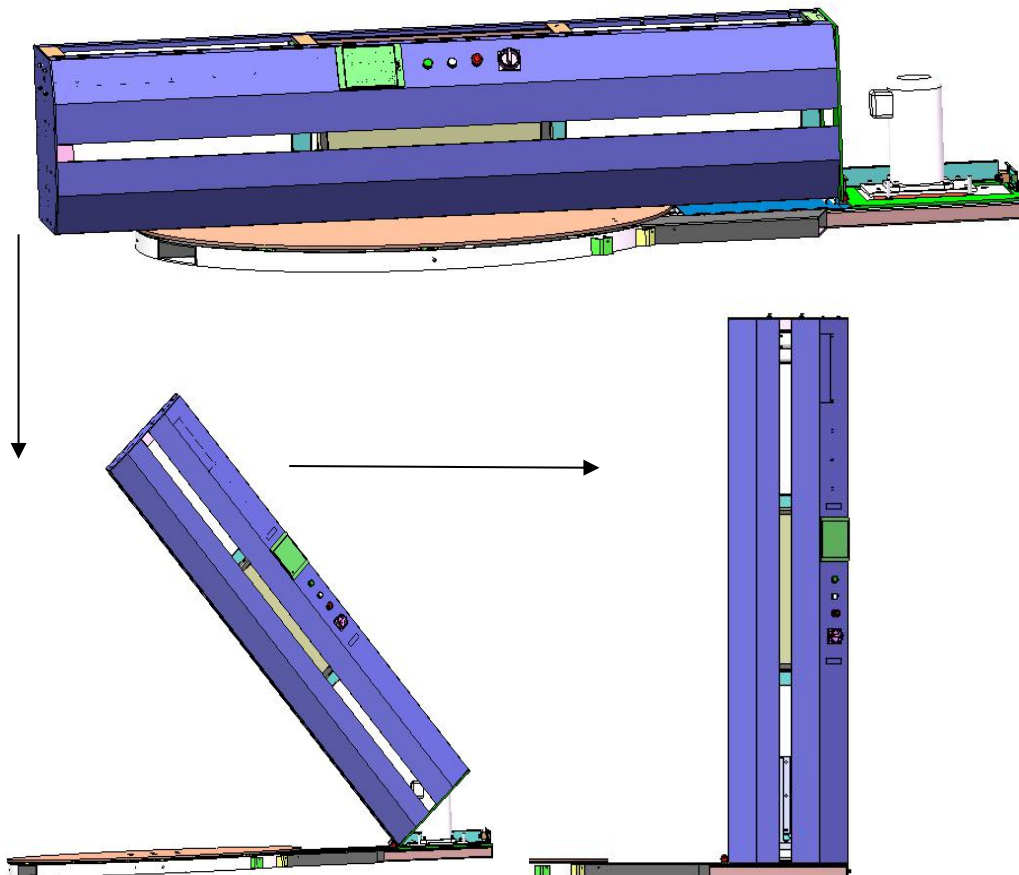

B.the four sets of fasteners are fixed on the chassis frame (external two groups, Internal two groups).

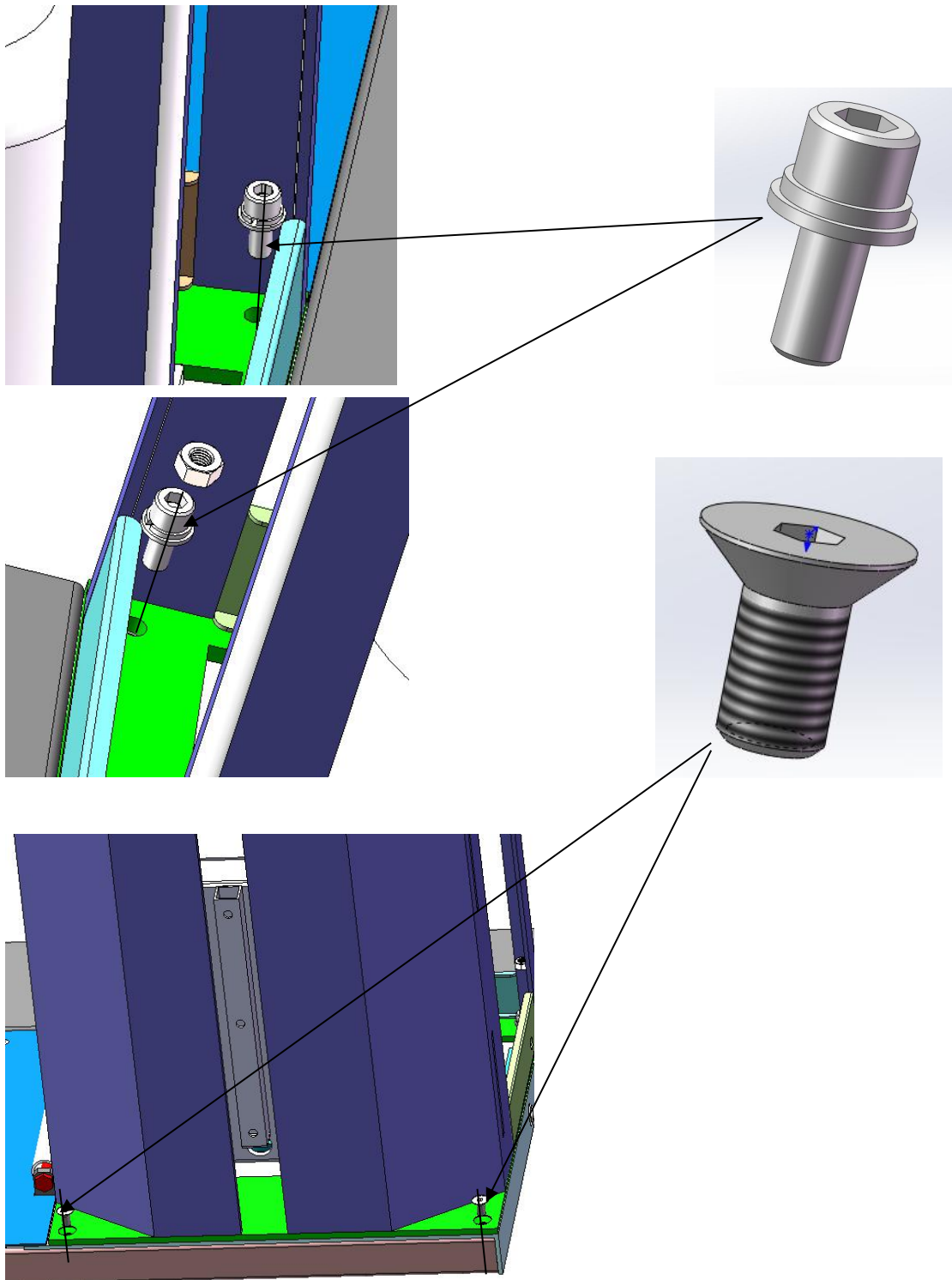

C.after the column and the chassis fixed then insert the column down fixed axis, using M12 round nut to lock

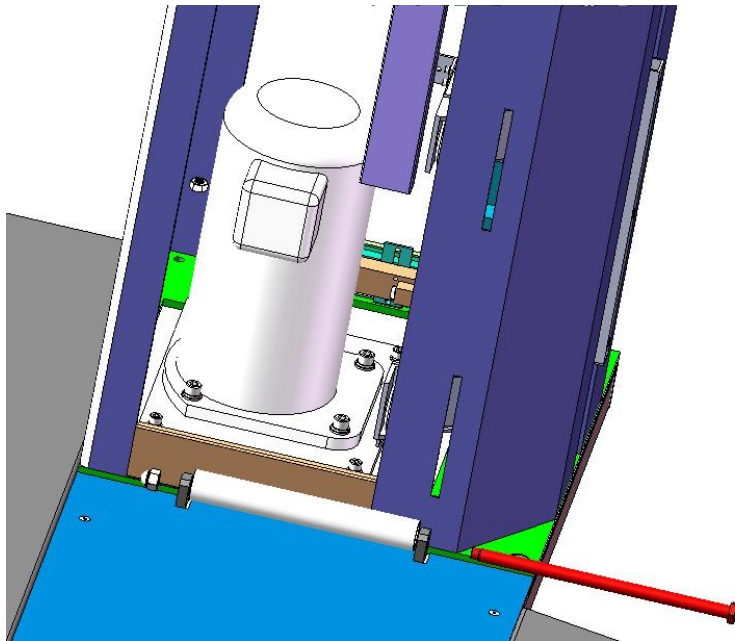

D.connect chassis motor aviation plug and the column aviation plug

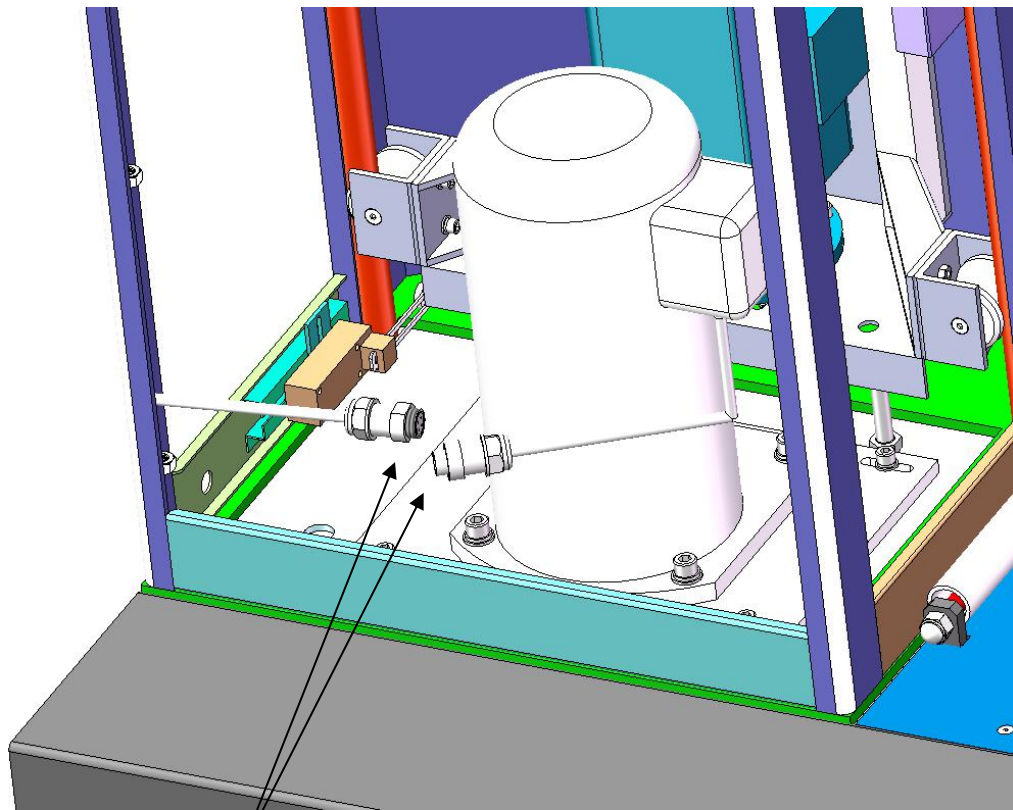

connect aviation plug

E.connect chassis aviation plug and the column aviation plug

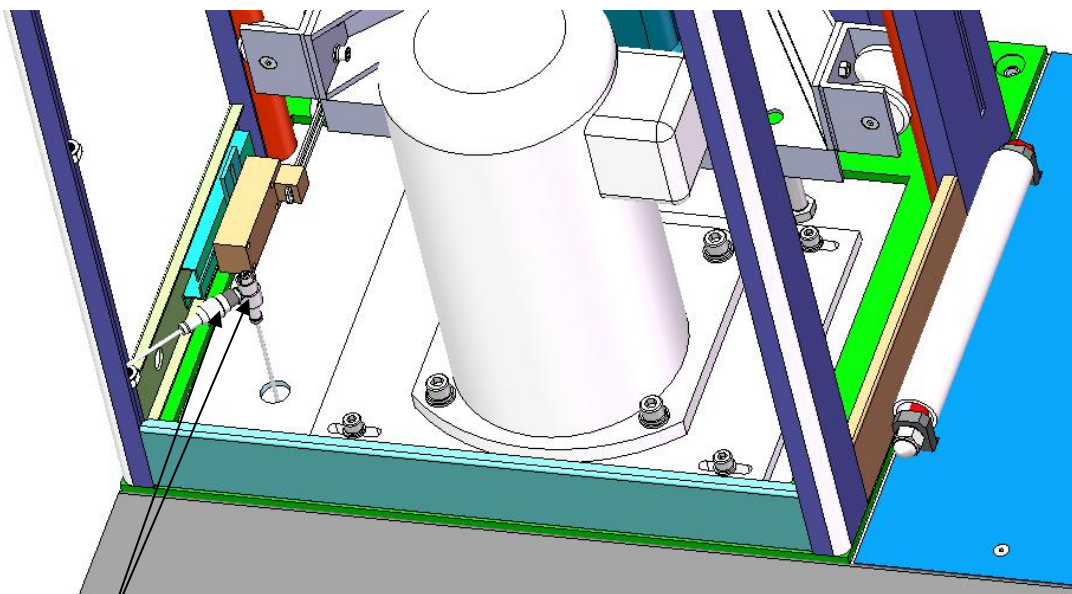

connect aviation plug

2.2 film carriage installation

- A. lift the lifter then place the lifter fixed block beneath it
- B. film hanging from a pillar outside on the lifter (note that when the hook connector through threaded hole below the hook plate to lift the body)

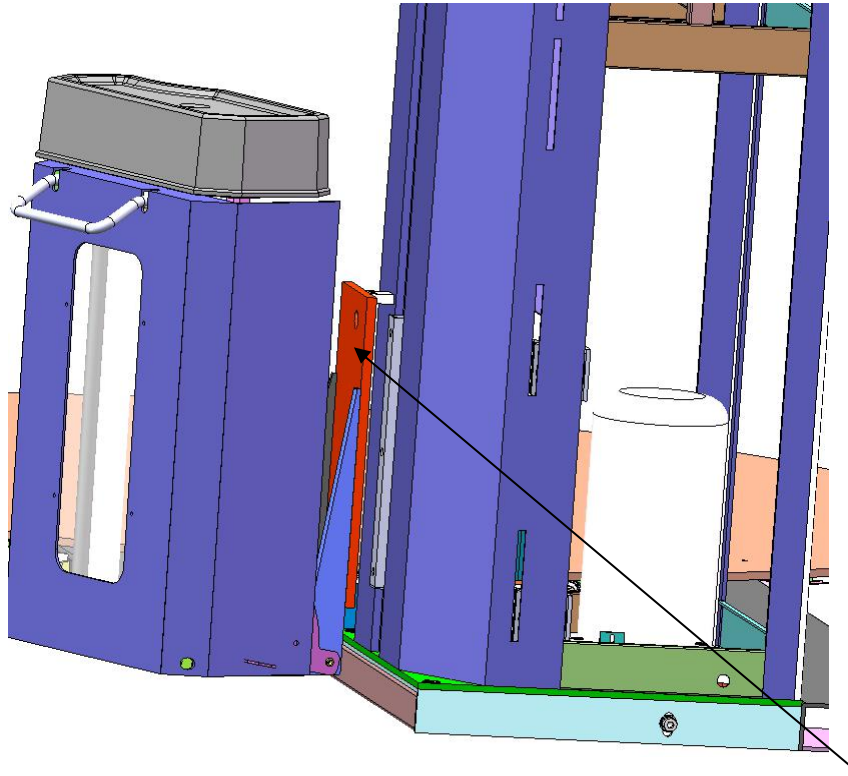

The film carriage is hung on the lifting.

C. using the corresponding bolt to fix the film carriage and the lifting body (note at the bottom of a group of tension film seat Tension bolt)

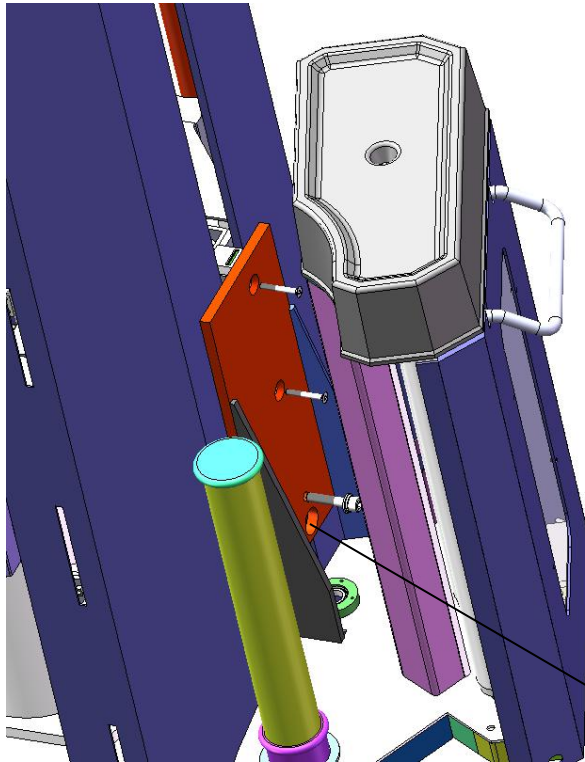

connecting wire through the hole to

the equipment

D.aviation plug through film carriage connect to aviation plug in tank chain

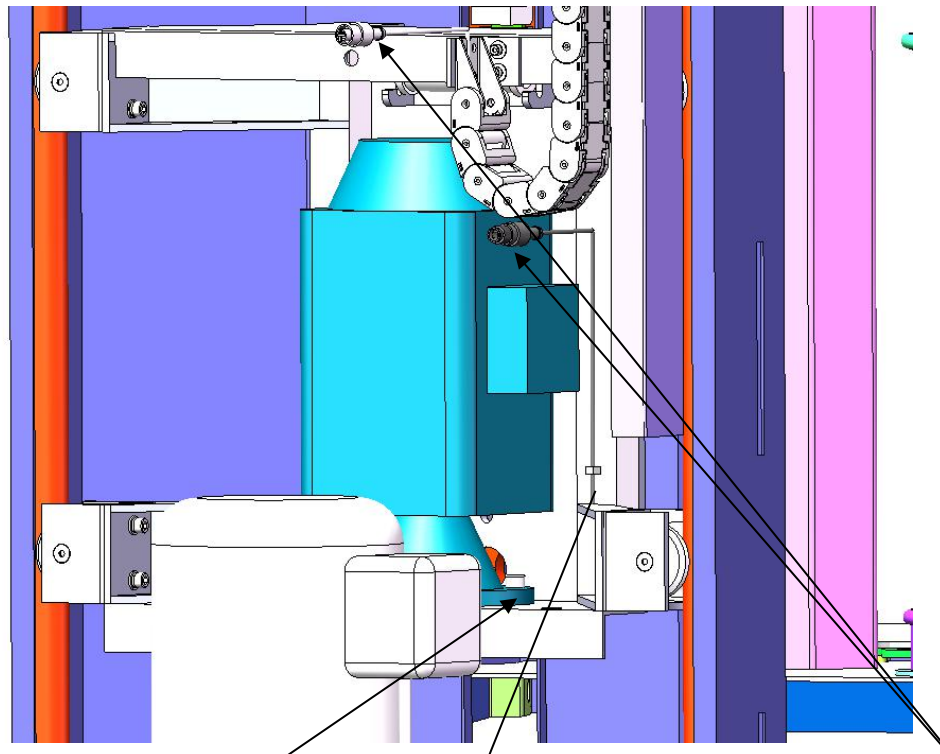

Connection lines are drawn from the hole
Connecting wire fixing nut

connect aviation plug

2.5 film carriage power connection

A.checking all wire connection if is safe,after confirming the safety and effective grounding connect equipment power supply and open the power switch.

B. after the start of the machine to switch to the manual page on the touch screen and click "mold up"to make the film carriage block up 50-60CM, and click to stop ,the specific operation method see the "operating instructions" section.(see picture)

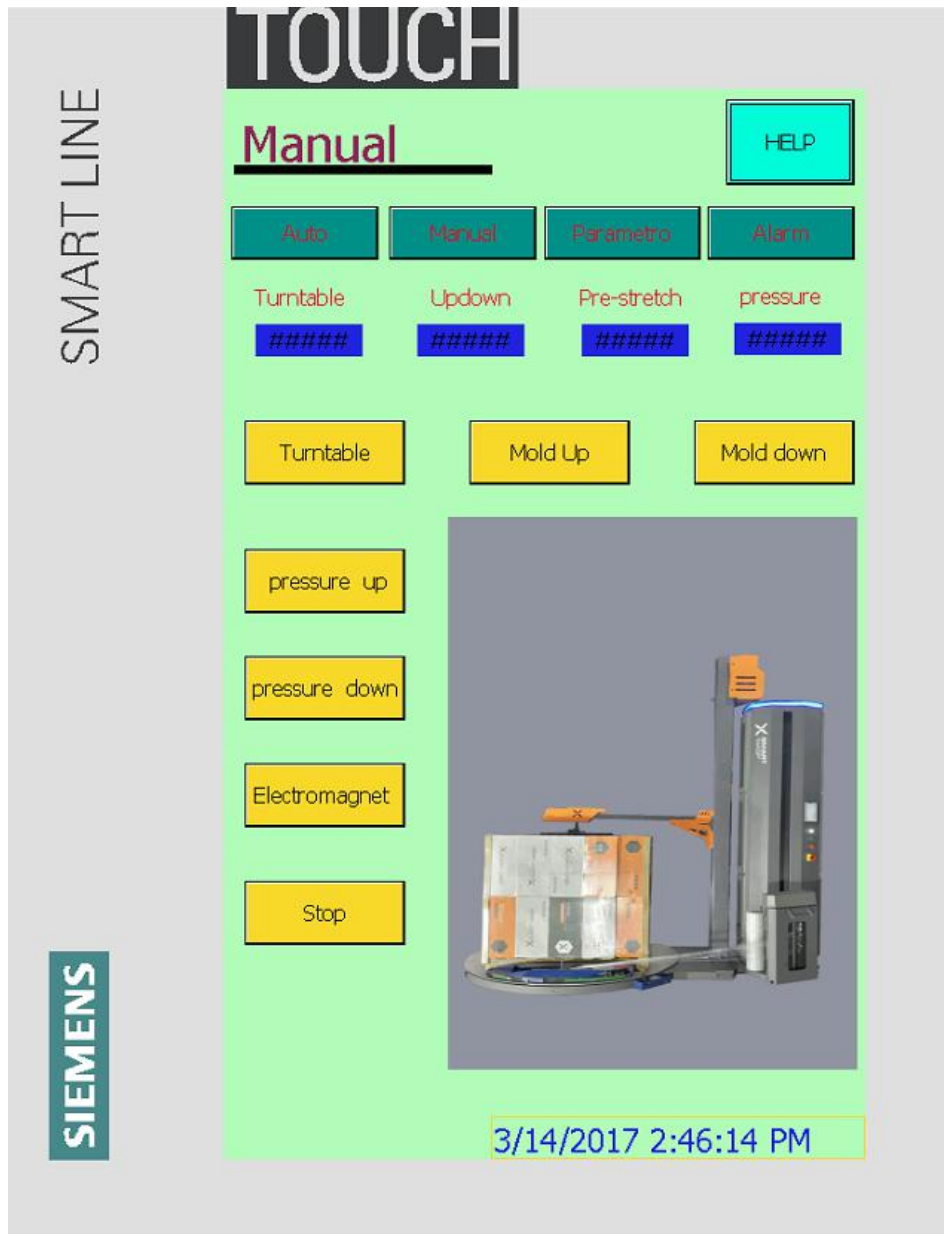

C. remove the film carriage motor fastening nut assembly and set the drive chain, then fastening screw on the fastening nut by hand.

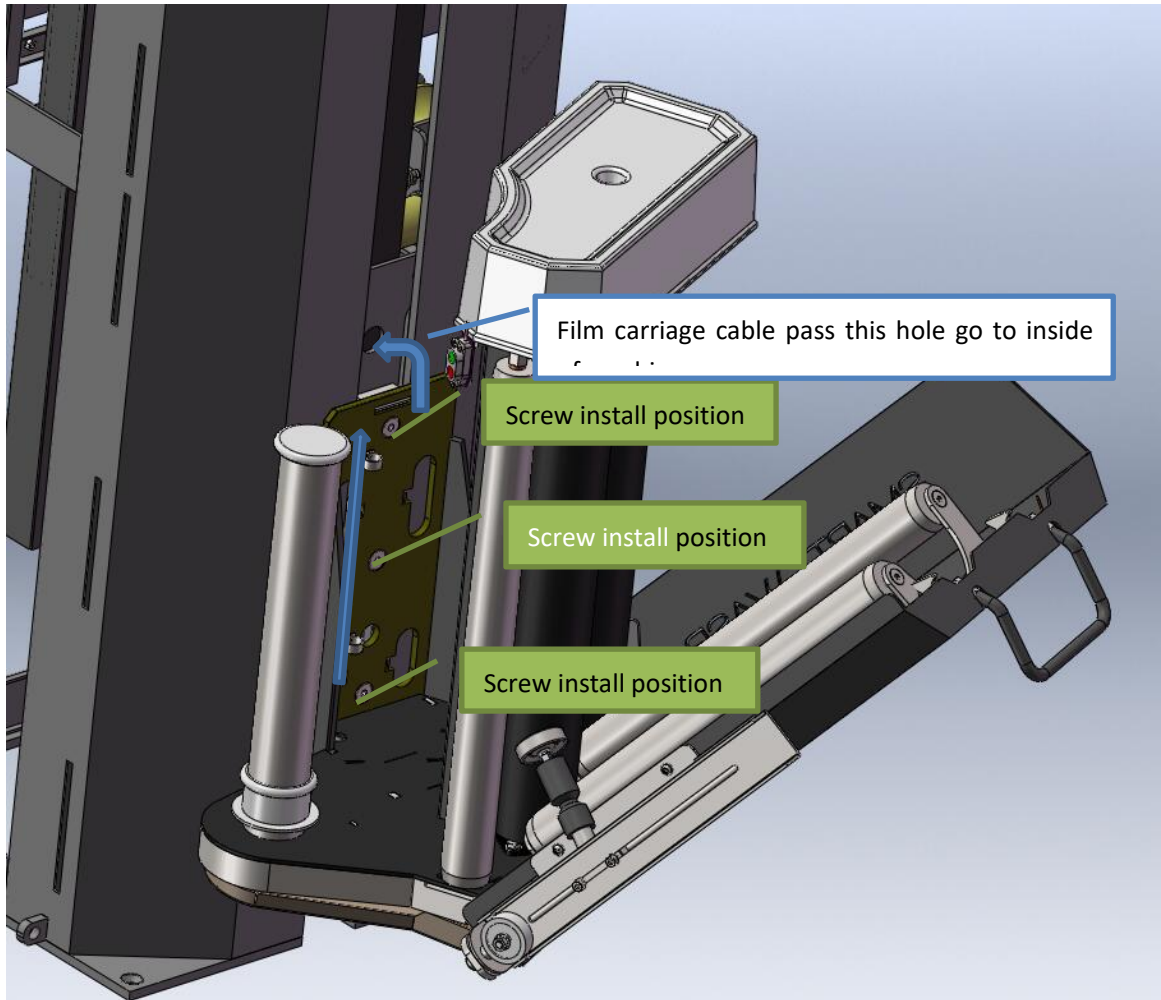

Picture 4.4

(3) The film base leads to quick connector and chain for quick connector

connection (see picture 4.5)The cable is fixed to the lifting body by a tie band.

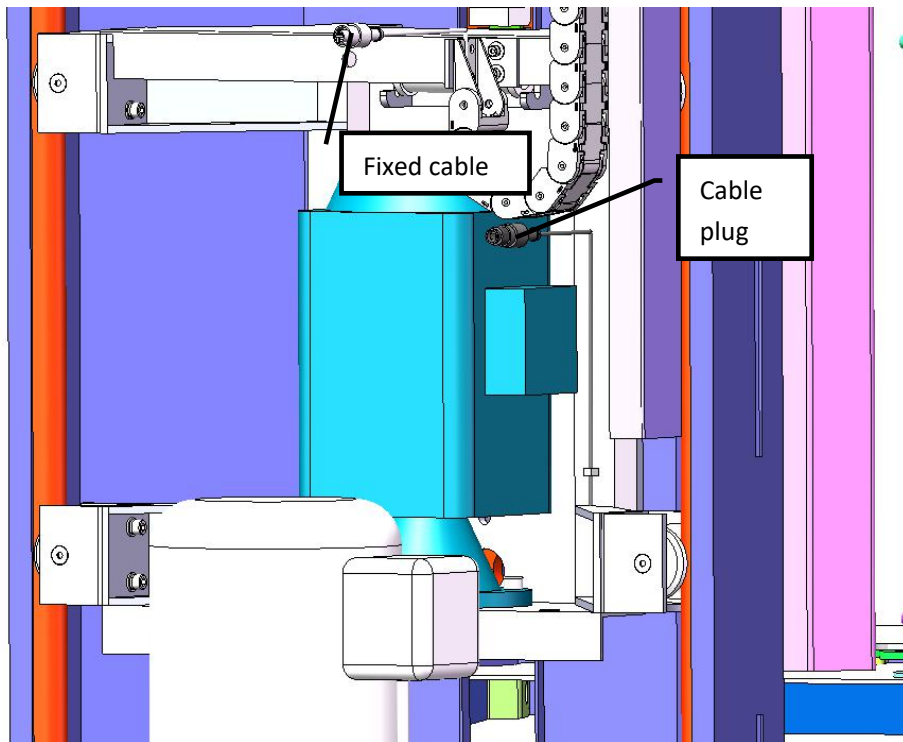

Picture 4.5

4.2.4 Film carriage power connection

- (1) Check the safety of all the wires of the equipment and confirm the connection of the equipment. Turn on the power switch
- (2) After the machine starts, switch to the manual screen on the touch screen (see “5、 human-machine interface introduction” picture 5.3 manual interface) , click “rise” lift the lifting body together with the film carriage to a suitable height (About shoulder leveling, easy to install the bottom of the film carriage), click rise again.

(Button change) stop it, see “Operating instructions” .

- (3) Rotate the safety screw for the membrane compartment, open the membrane seat safety plate, and then tighten the fastening nut, (see picture 4.6, 4.7)

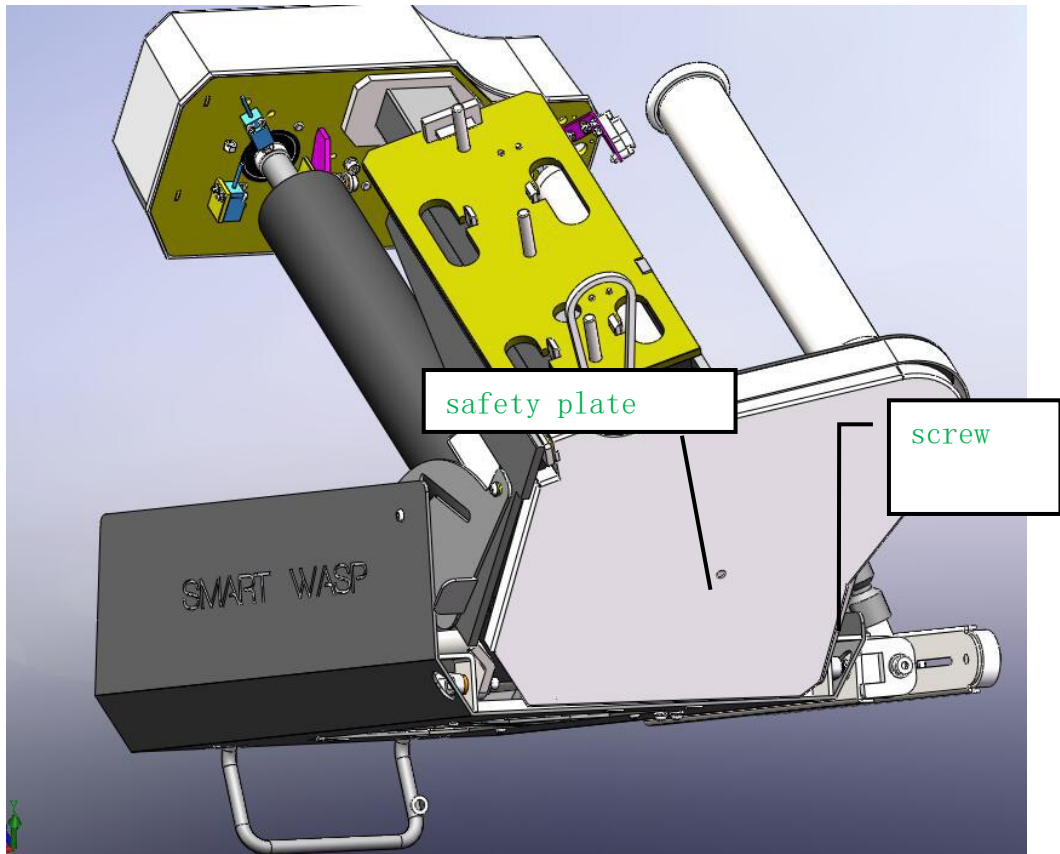

Picture 4.6

Picture 4.7

- (1) Put on the chain, install tensioning sprocket and adjust screw tightness as the following pictures show.

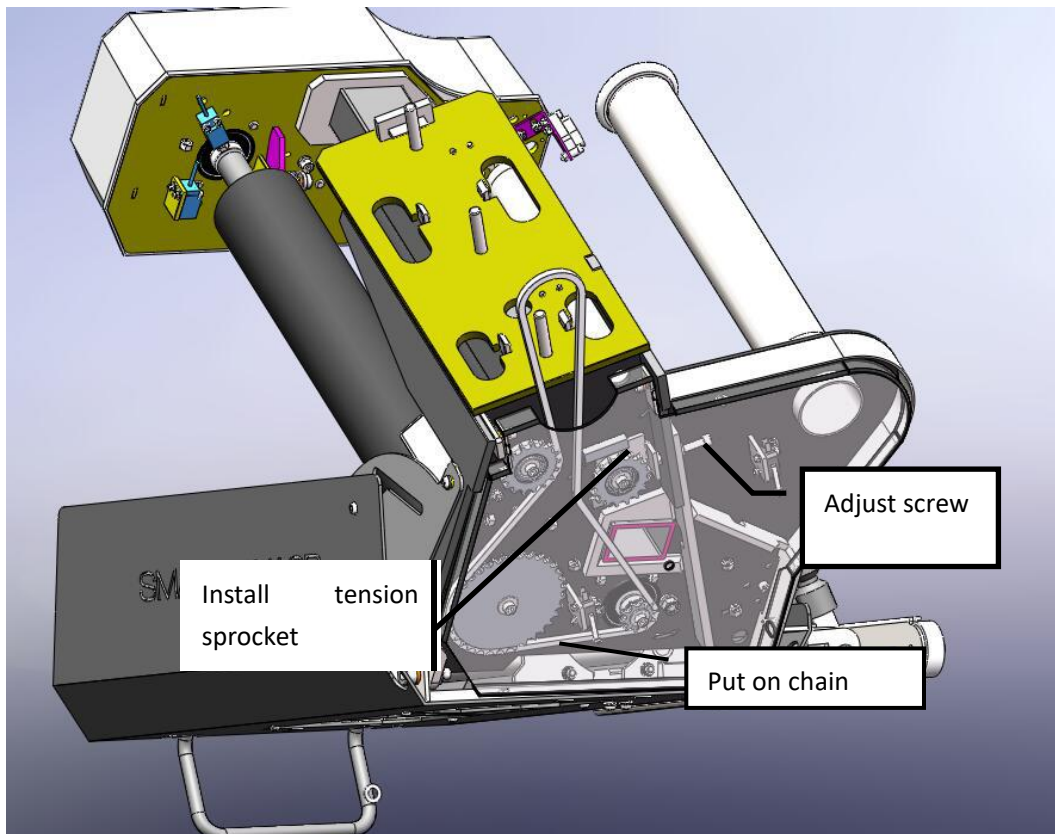
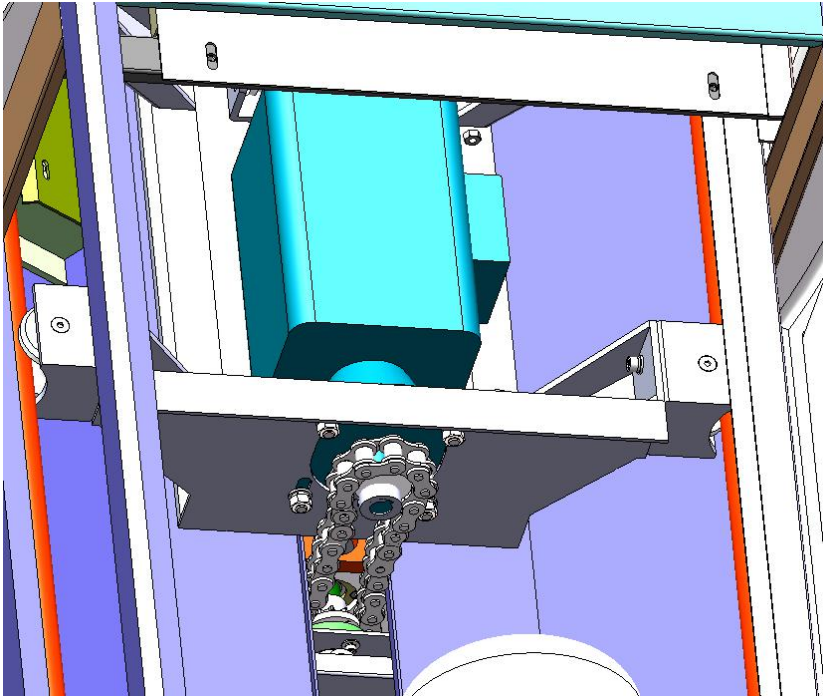

Close the safety plate of the film carriage, and turn the safety screw into the square hole

Decline the body together with the film carriage in a manual manner to a minimum

2.6 door installation

A .front door installation, put door clasp into door slot and door crack

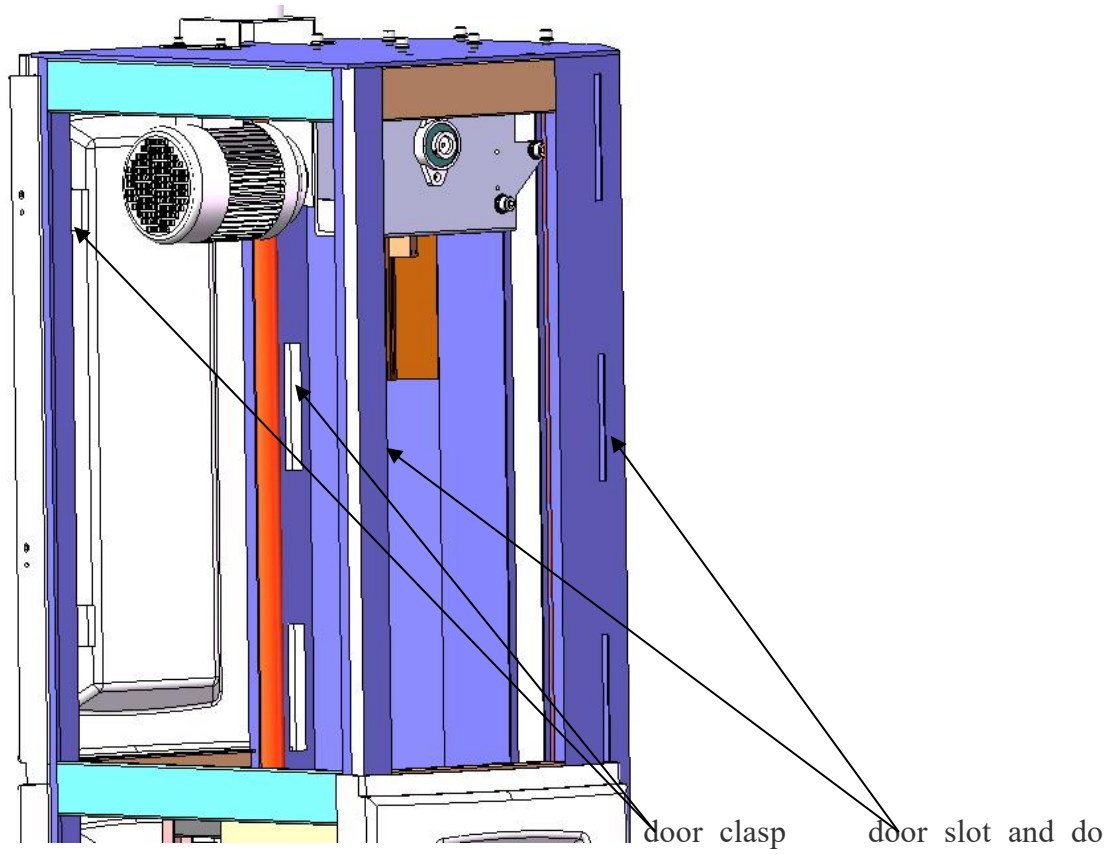

or crack

B.back door installation(door slot) put door clasp into door slot and door crack

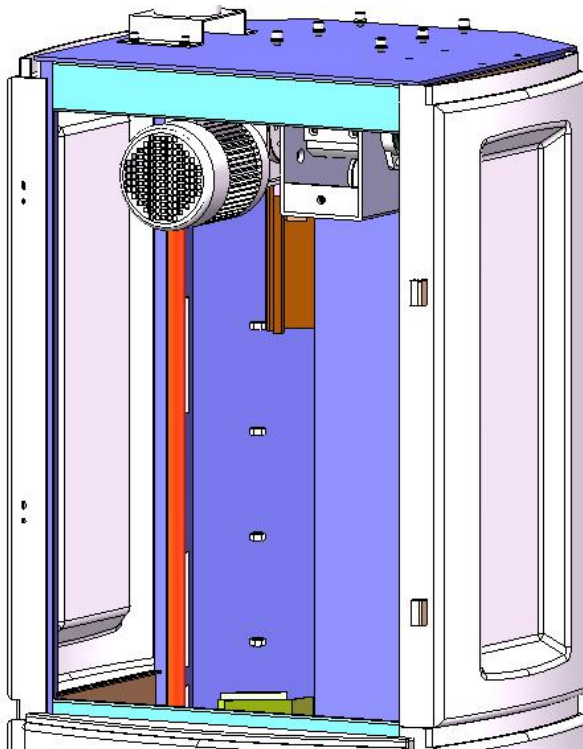

C .The side door installation. put Upper door clasp into lower door clasp

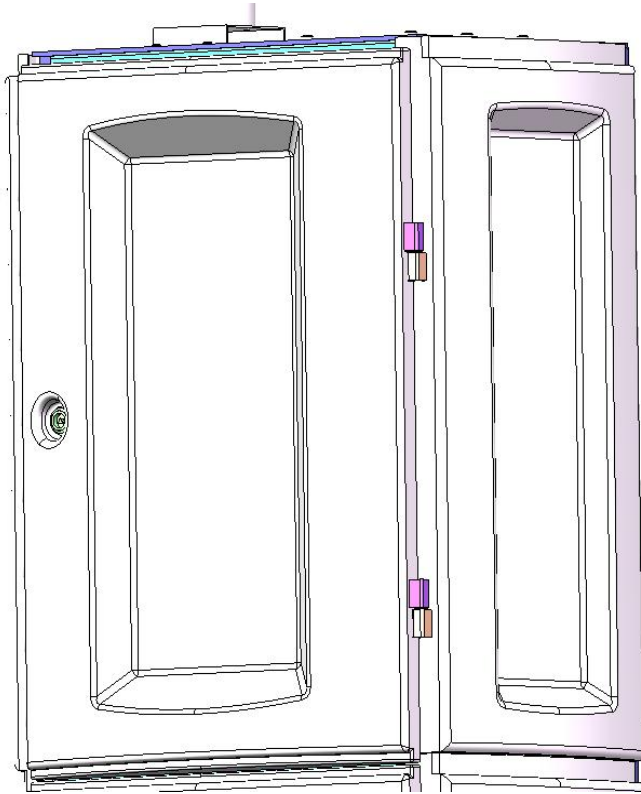

2.7. tidy the wire

Tidy all the wires and fix them with band.

2.8. Top Pressure device installation

After install the door and cable inside of the machine ,and then install the top plate on the machine

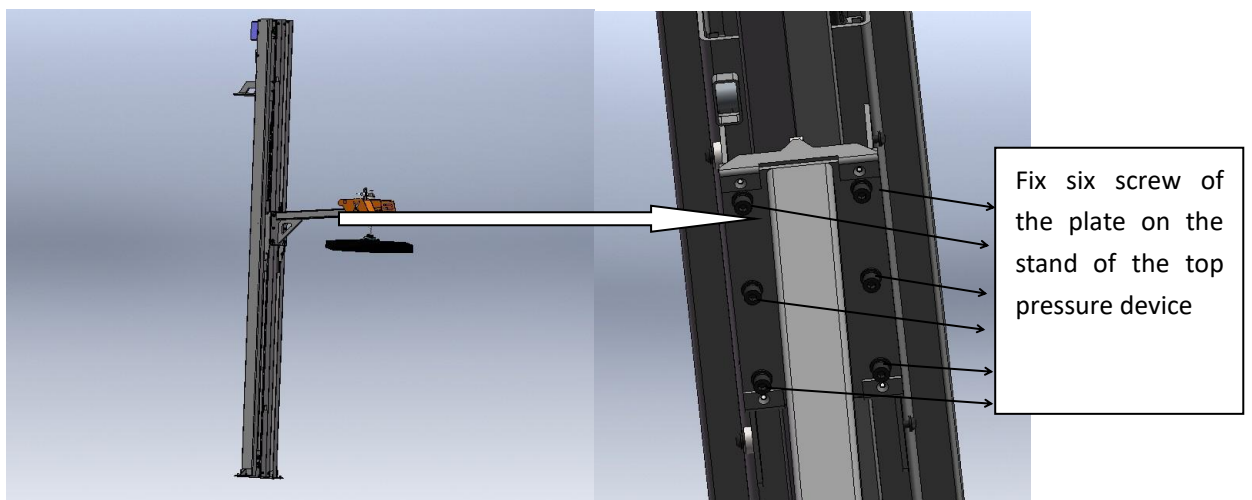

Fix the plate on the top pressure device stand and the link the cable from the top plate to the stands.

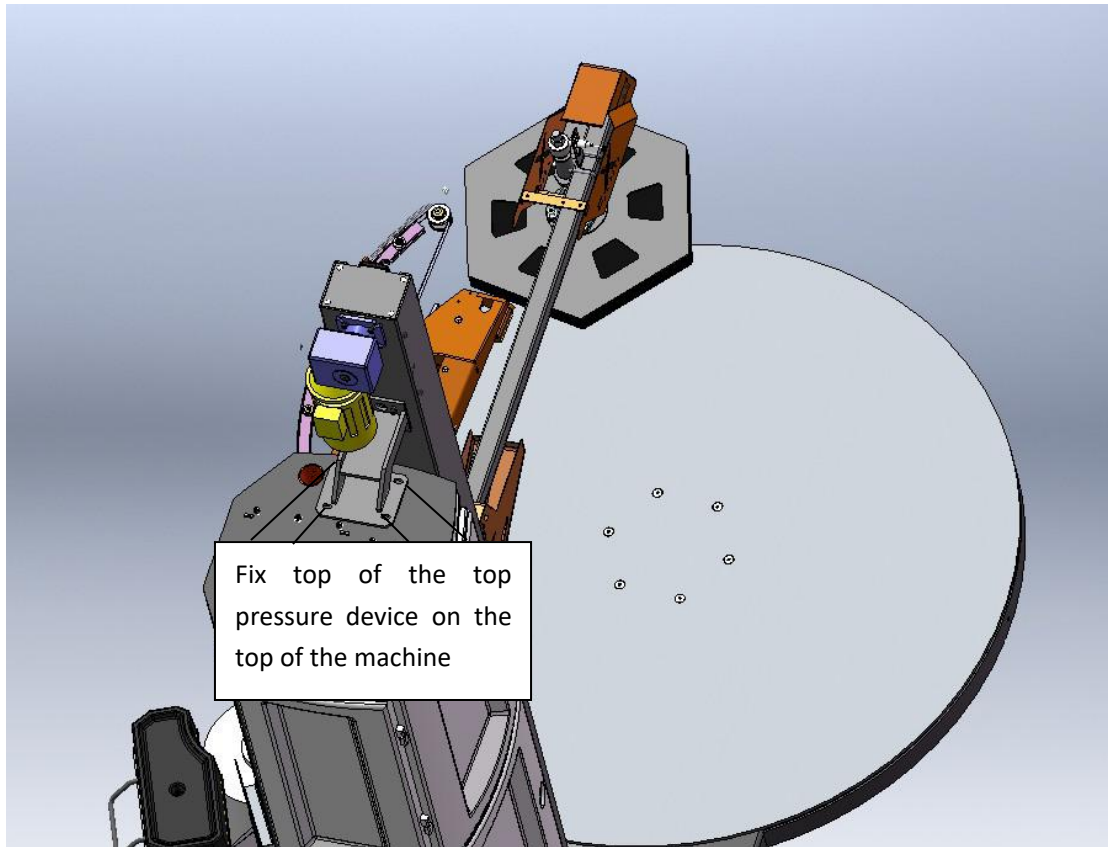

After this step please link the cable from the top pressure device to the machine .

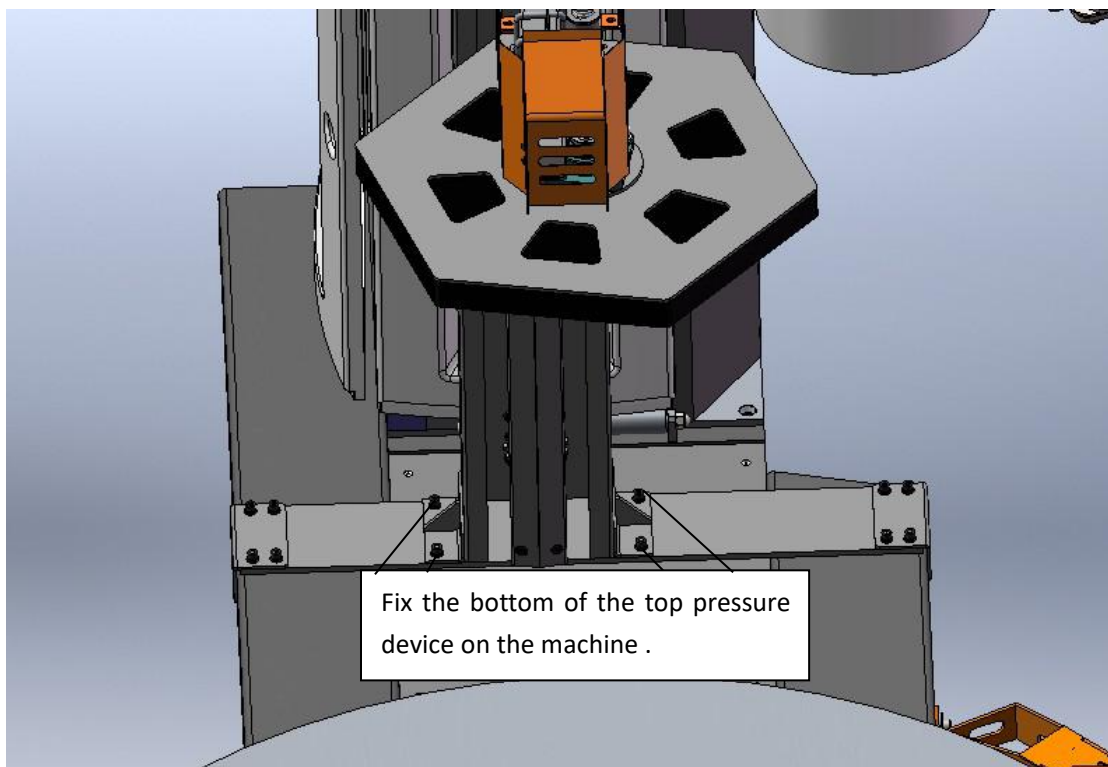

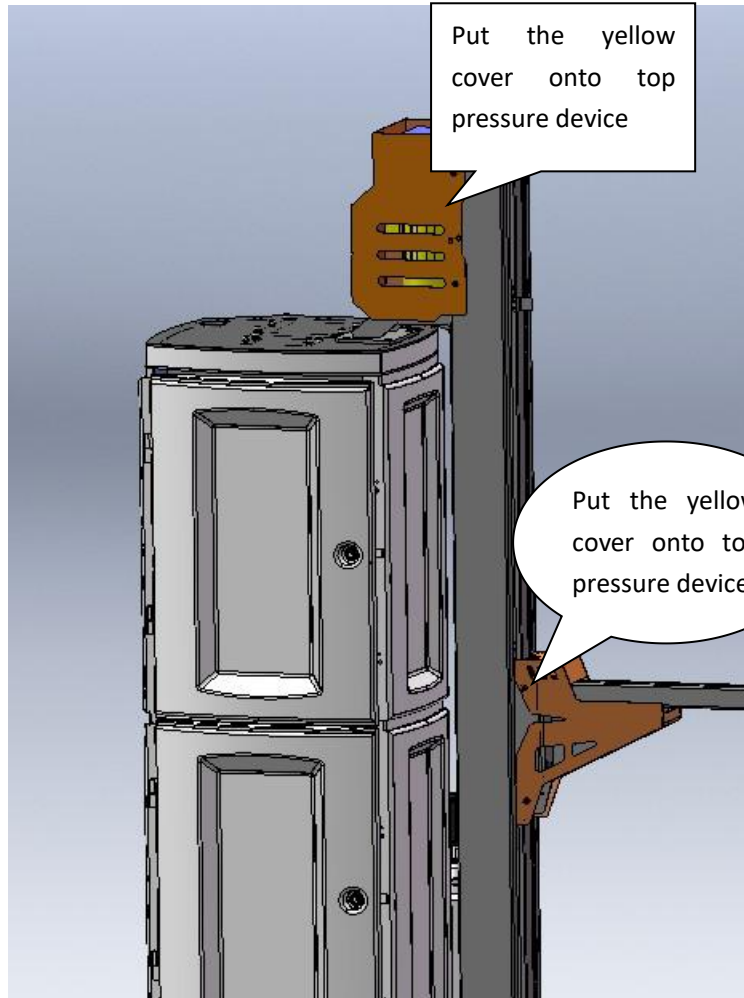

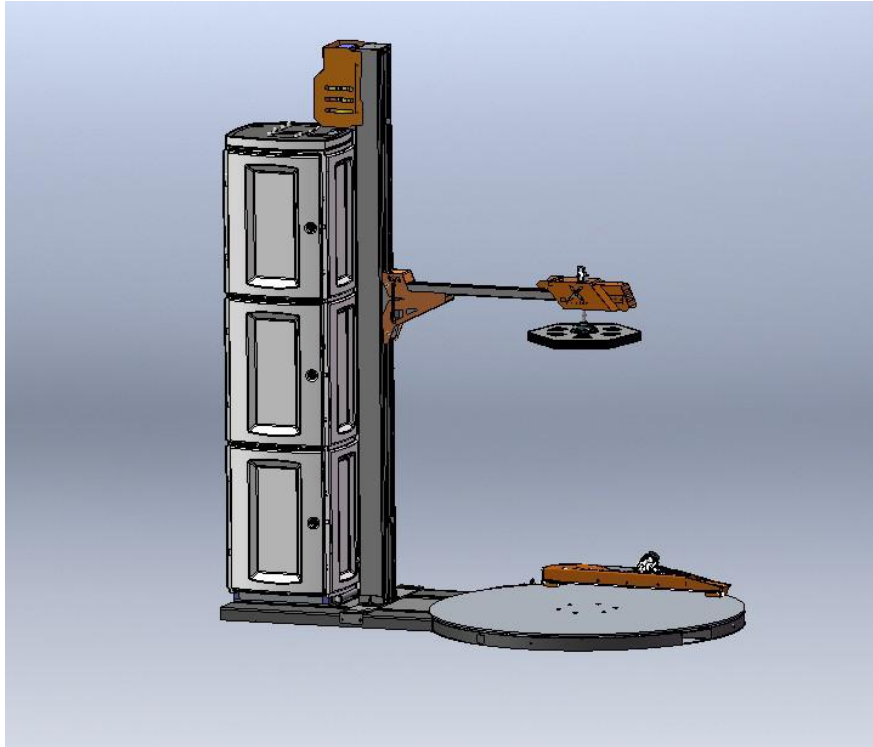

3 test equipment

3.1 matters needing attention

A. please confirm the use of the machine power supply, do not plug the wrong power, the machine uses a single phase AC220V, the dual color line for the ground, from the protection

B. When the machine is running, it is strictly prohibited to put the foot on the machine.

C. not allowed to install the machine on the soft ground

D. not allow the object to be wrapped around the disc edge

E. emergency, can press the emergency stop switch, disconnect the motor power supply, so that the machine emergency stop

F. after the completion of the work of the day, please clean the machine once

G. in order to ensure safety, please do not arbitrarily open electrical equipment

H. only electrical technician can repair electrical equipment

3.2 test preparation

A. to check the correctness of electrical connection, and to ensure that the ground safety ground

B. to check whether the installation bolt is missing, and confirm its tightness

C. to confirm the equipment turnover no debris, tools and spare parts have been completed

D. confirm that the height of the photoelectric direction is not more than the edge of the minimum product

3.3 equipment pretest



watch out!:

To carry out any of the following operations, The other hand should be placed in the "emergency stop" button, to be able to press "emergency stop" in the first time, and find the problem, when the problem has not been resolved do not follow the steps (problem solving methods, see "six, deliberately excluded)

A. connect the power supply and turn on the power switch, waiting for the system to start

B. with a finger tap into the "manual screen" (see photo)

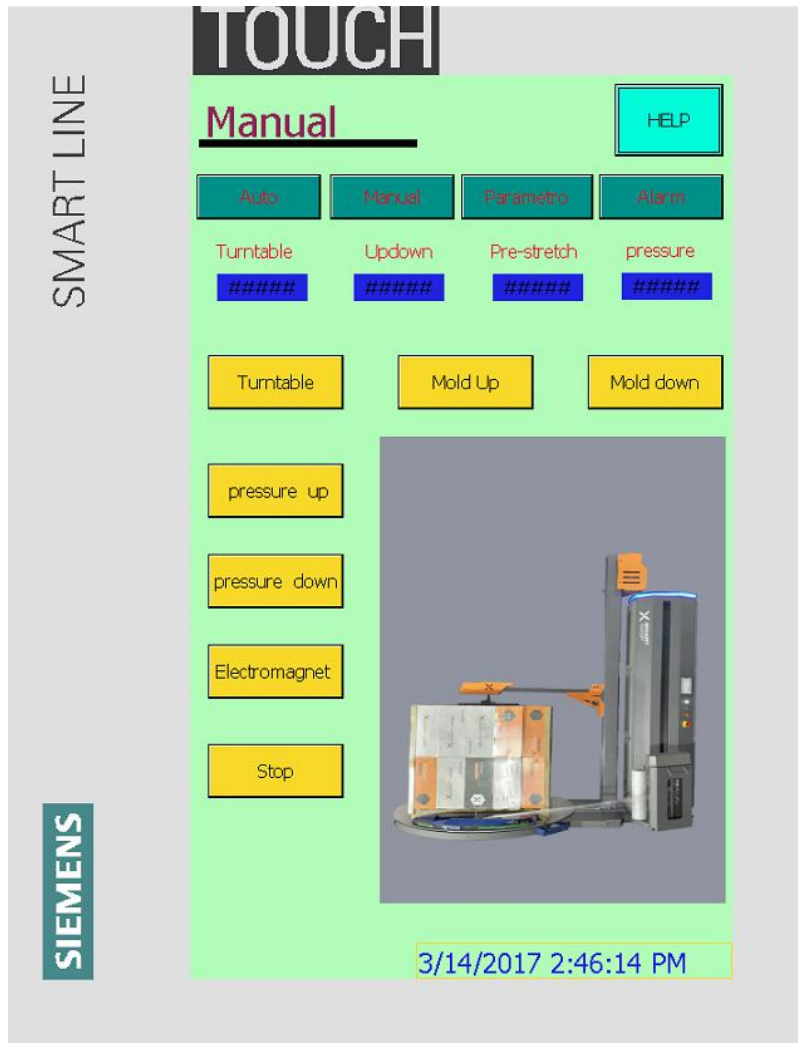

C. click on the "turntable" button to try to turn the turntable, confirm the "turntable" easy to start and no abnormal sound after the click again to stop

D. click on the "mold up" button will rise to the top of the device will be raised automatically stop, confirm the rise of smooth without blocking



watch out!:

A.when the device stops, please observe the lift in the column should have touched the upper limit of the travel switch (see photo)

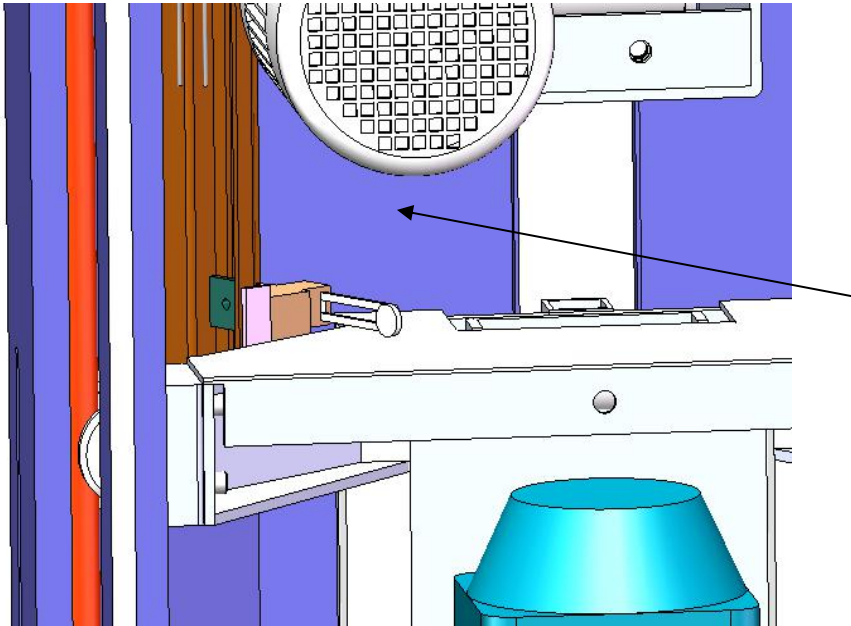

B. click on the "down" button to move the film seat down, move to 1M height, click "stop" to confirm the smooth without blocking

C. click the "electromagnet" button, Observation of blocking device is normal up (see photo)



watch out!:

No matter blocking device whether bounce, should click the "electromagnet" button in the 5S to turn it off (to avoid long time electricity burn)

After the automatic reset, the lifting body should have touched the end of the limit of the travel switch (see photo)

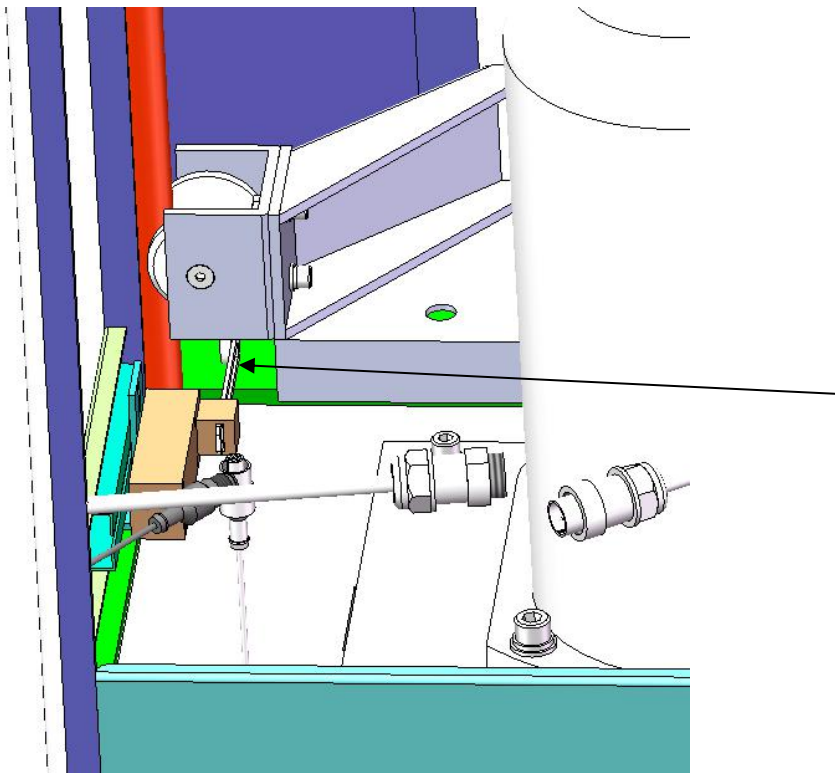

3 device parameters

name	parameter
supply voltage	AC220V、 50Hz、 0.8KW (drag pull、 1.2KW(pre pull)
turntable	Speed 0-13r/min
Lifting body	Limit or adjust film winding height standard
Film tensile component	The tightness of the film can be adjusted automatically by equency conversion, and the tension of the film can be adjusted automatically.

	The film can be controlled by the adjustment of the handle.
film	The maximum thickness of the film is 0.035MM
	The diameter of the shaft diameter phi 50-75MM thin film
	The maximum diameter of less than 250MM films
	Film width is 500MM
Packing object	The maximum packing weight is 1500KG
	The maximum packing height is the total height of the column is reduced by 400MM
enclosure	Slope body
Machine size	Turntable diameter is phi 1500:2340*1500*H (2000 ~ 3000) can be customized
	Turntable diameter is phi 1650:2540*1650*H (2000 ~ 3000) can be customized
	Turntable diameter is phi 1800:2630*1800*H (2000 ~ 3000) can be customized
	Turntable diameter is phi 2000:8440*2000*H (2000 ~ 3000) can be customized
Machine weight	650KG
Working noise	Working noise
environment condition	The temperature is less than or equal to 98% temperature 0-40

4 Equipment introduction

1. overview of devices and Applications

This machine is widely used in chemical fiber, tobacco, pharmaceutical, publishing, refrigeration, home appliances, ceramics, hardware, chemical industry, cans and other industries, high production efficiency to prevent the goods damaged in the process of handling, and dust, moisture-proof and cleaning effect. As the winding machine of the revolution, the device also has general winding machine has the following advantages:

A. high efficiency, energy saving, stability, (a) automatic cutting film saving artificial 180 seconds, Hengli membrane to avoid damage to the product, and save more than

30% of the consumables, automatic rope to avoid products falling from the pallet and finish all this in silence, 3 years warranty, jsk is winding packaging revolution.

(b) industry leading jsk intelligent LCD touch screen, the operation is extremely simple, containing cover operating instructions, troubleshooting, at a glance, a button.

B. intelligent, convenient: equipped with intelligent remote control device DriveX, forklift workers do not need to get off, just gently a key, you can complete the automatic packaging process, a remote control can be remotely controlled by a number of machines.

C. no gas, no fault of the automatic cutting film: with jsk patent drive x automatic cutting film system is a revolution, without gas drive, only you can control the weak, decreasing the size of the requirements for the use of the environment. Only artificial goods placed on pallets and the start button will automatically film winding in the goods, without any waste. When the wound after packaging, it will automatically cut off the film. On one side of the membrane will perfect adhesion goods, packaging, side machine on the membrane and is ready packaging a cargo tray, the whole process without artificial participation.

D. constant a membrane system: special constant a membrane system, the adverse effects in at the corner of the products and plane membrane of tightness of the same, and wrapped the tightness can be through the touch screen control, fundamentally solve the general winding machine winding products (especially the length and width of the gap is larger) Shi Guai angle is tight planar Chi.

E. wrap rope system: at the bottom of the local rope enhances the degree of products and the pallet with fastening, even when subjected to severe vibration, air cannot slide from the pallet. And it can solve the forklift pallet on the bottom of the spiral wound membrane damage. Throughout the rope enhances the overall goods wrapped around the strength of the packaging, reduce the transportation damage to the product. The whole and local rope will completely replace traditional horizontal packaged.

F. ABS and metal unique combination: bearing metal frame, coupled with the ABS panel, the perfect combination, not only reduces the overall weight of the machine, but also to make the panel has a collision buffer function, and beautiful and full of texture.

2 . introduction of the whole machine

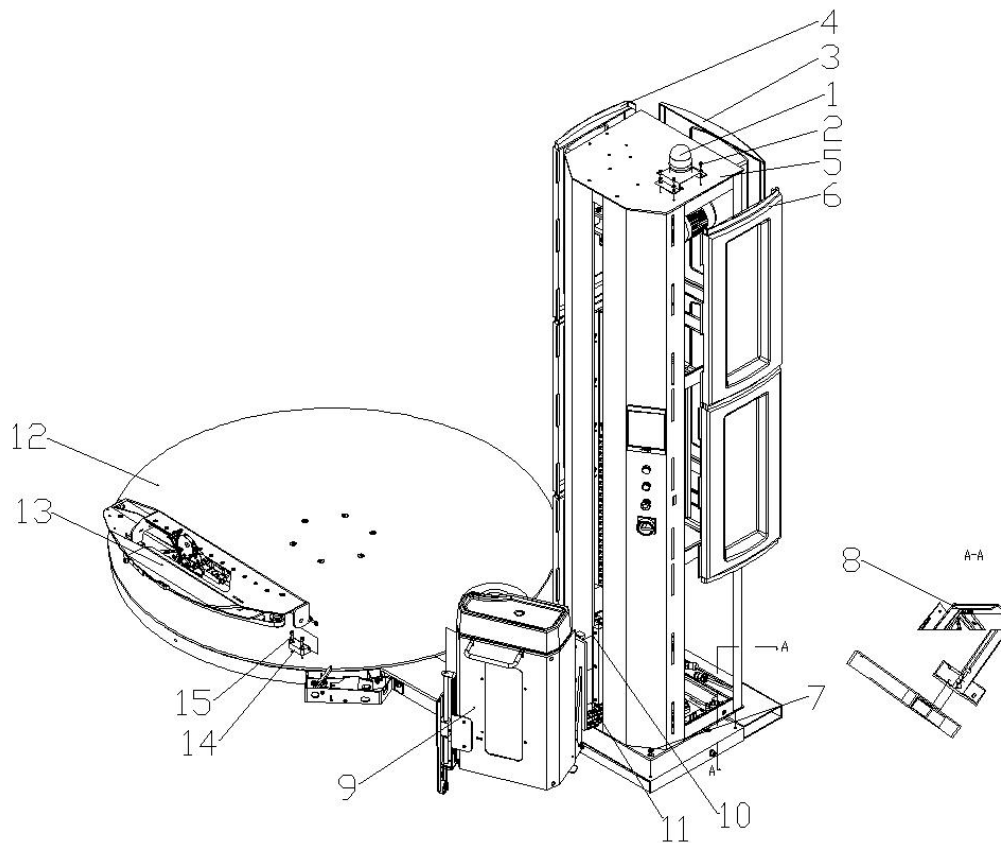
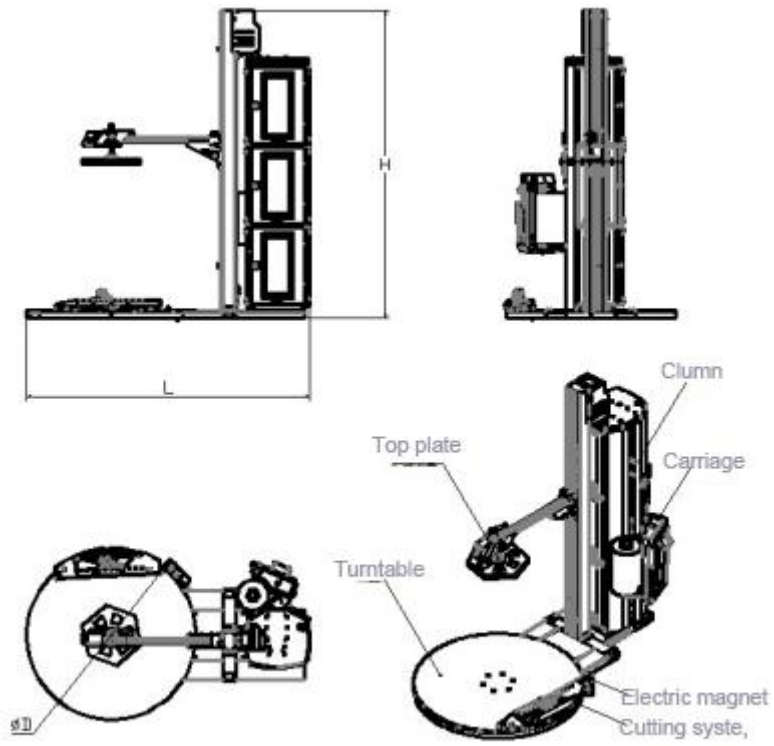

Serial no.	Drawing no.	Part name	no.
1		Alarm device	1
2		Alarm fixed screws	4
3	916B-0201-P023	Side door panel	3
4	916B-0201-P022	rear door panel	3
5	916B-0201-PA01	columns	1
6	916B-0201-P021	Front Door panel	3
7		columns install screw	2
8		columns install screw	2
9	916B-0201-SA01	film carriage	1
10		film carriage install screw	2
11		film carriage the chain tension screw	1
12	916B-0201-NA01	Chassis	1
13	916B-0201-CA01	Cutting system	1
14	916B-0201-C014	Cutting system Fixed block	2
15		Cutting system install screw	6

3. column

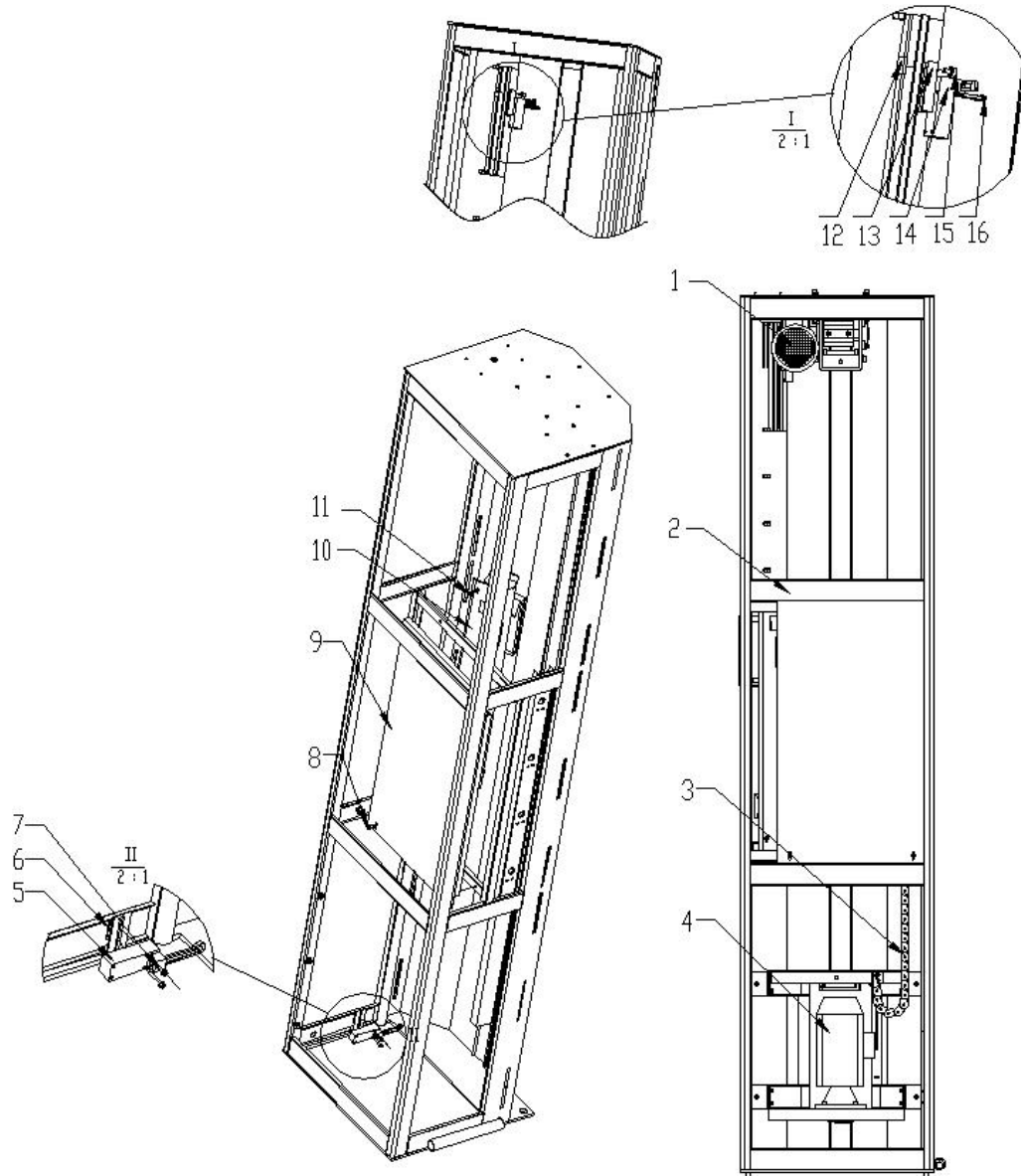

Serial no.	Part name	Drawing no.	no.
1	Up&down power unit	916B-0201-QA02	1
2	columns	916B-0201-PA01	1
3	Up&down Tank chain		1
4	Up&down install	916B-0201-QA04	1
5	Micro switch		1
6	Micro switch Fixed nut	916B-0201-N013	8
7	M4*30 screw/Spring gasket/Flat gasket		4
8	M5*12 screw/Spring gasket/Flat gasket		2
9	Distribution board	916B-0201-P006	1
10	Electrical shield plate	916B-0201-P007	1
11	M5*12 screw/Spring gasket/Flat gasket	916B-0201-Q011	4
12	Travel switch positioning nut	916B-0201-P019	1
13	Travel switch positioning board	916B-0201-P018	1
14	Micro switch		1
15	M6*12 screw/Spring gasket/Flat gasket		1
16	M4*30 screw/Spring gasket/Flat gasket		1

3.1 Lifting and moving group

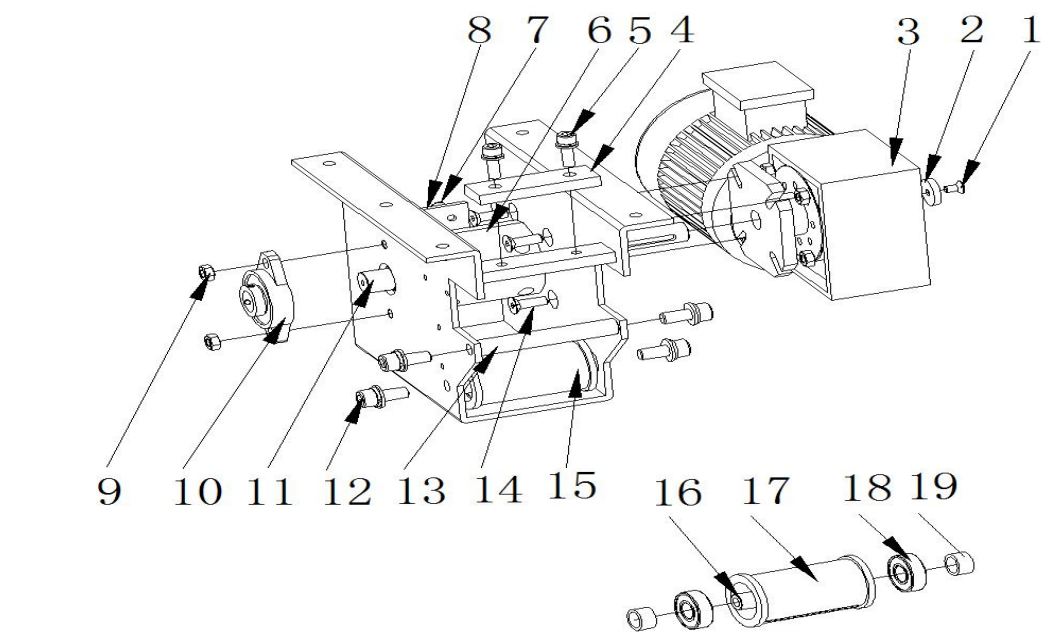

Serial no.	Part name	Drawing no.	no.
1	M6*15 Flat head screw		1
2	Limit piece	916B-0201-Q014	1
3	Up&down motor	916B-0201-Q030	1
4	Bag keep plate	916B-0201-Q013	1
5	M8*25 screw/Spring gasket/Flat gasket		2
6	Receives the belt clamp cover	916B-0201-Q018	1
7	M6*15 flat screw		2
8	Top belt Guide shaft	916B-0201-Q012	1
9	M8 NUT		6
10	bearing block	916B-0201-Q032	1
11	Take-up shaft	916B-0201-Q019	1
12	M10*25 screw/Spring gasket/Flat gasket		4
13	Top belt Guide shaft	916B-0201-Q021	1
14	M8*25 Flat head screw	916B-0201-QA03	6
15	Receives the belt fixed pulley group		1
16	Top fixed axle	916B-0201-Q024	1
17	Top fixed body	916B-0201-Q020	1
18	Take-up with bearing	916B-0201-Q034	2
19	Top fixed axle sleeve	916B-0201-Q025	2

3.2 Lifting body

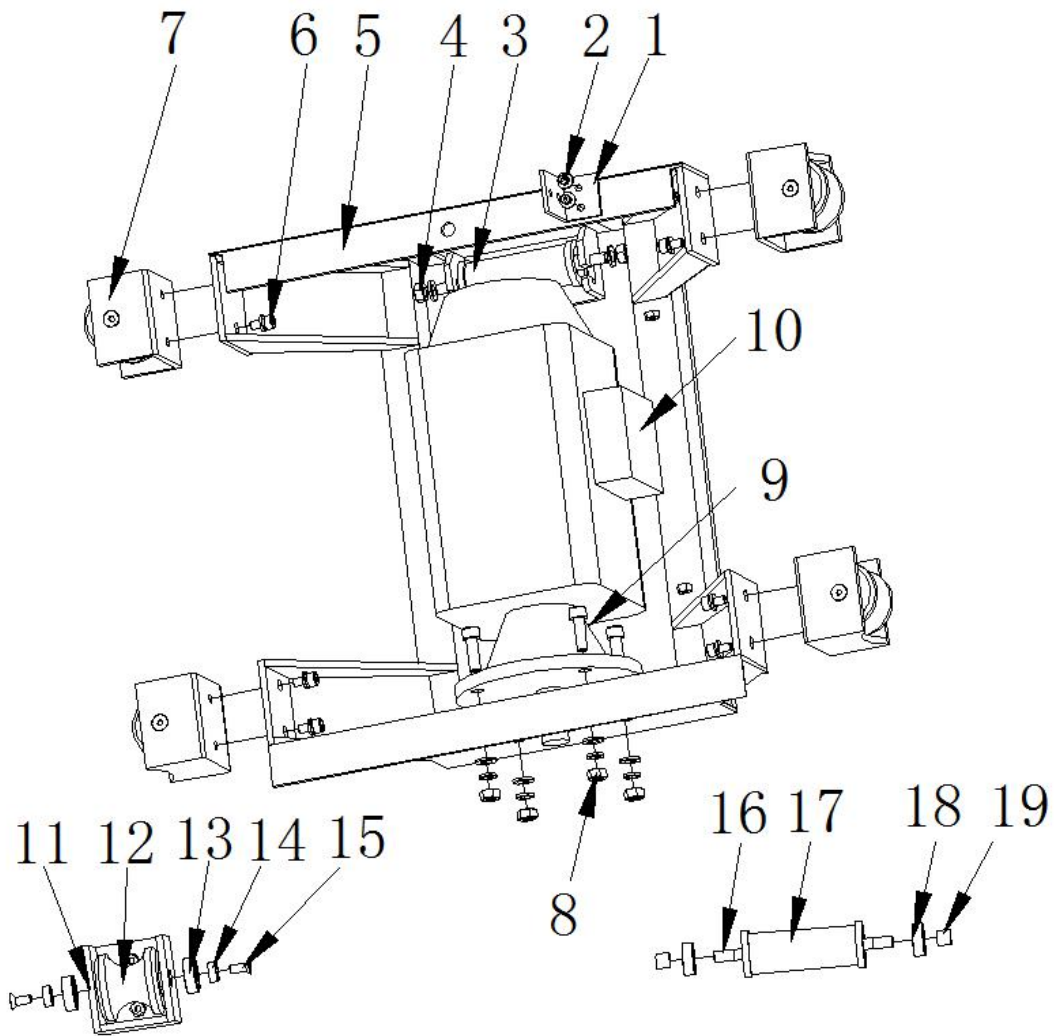

Serial no.	Part name	Drawing no.	no.
1	Leather belt activity end fixed plate	916B-0201-Q011	1
2	M4*12 screw/Spring gasket/Flat gasket		2
3	Up&down Hook the wheel	916B-0201-QA05	1
4	M8 screw/Spring gasket/Flat gasket		2
5	Up&down body	916B-0201-QA07	1
6	M6*12 screw/Spring gasket/Flat gasket		8
7	Guide wheel installment	916B-0201-QA06	4
8	M8 screw/Spring gasket/Flat gasket		4
9	M8*25 screw/Spring gasket/Flat gasket		4
10	Up&down motor	916B-0201-Q031	1
11	Guide wheel rack	916B-0201-Q011	4
12	Guide wheel	916B-0201-Q029	4
13	Guide wheel bearings	6000	8
14	Guide wheel axle sleeve	916B-0201-N028	8
15	M8*15 head screw		8
16	Up&down wheel axle	916B-0201-Q023	1
17	Up&down wheel body	916B-0201-Q022	1
18	Bearings for lifting hooks	916B-0201-Q035	2
19	Lifting wheel axle sleeve	916B-0201-Q026	2

4. chass

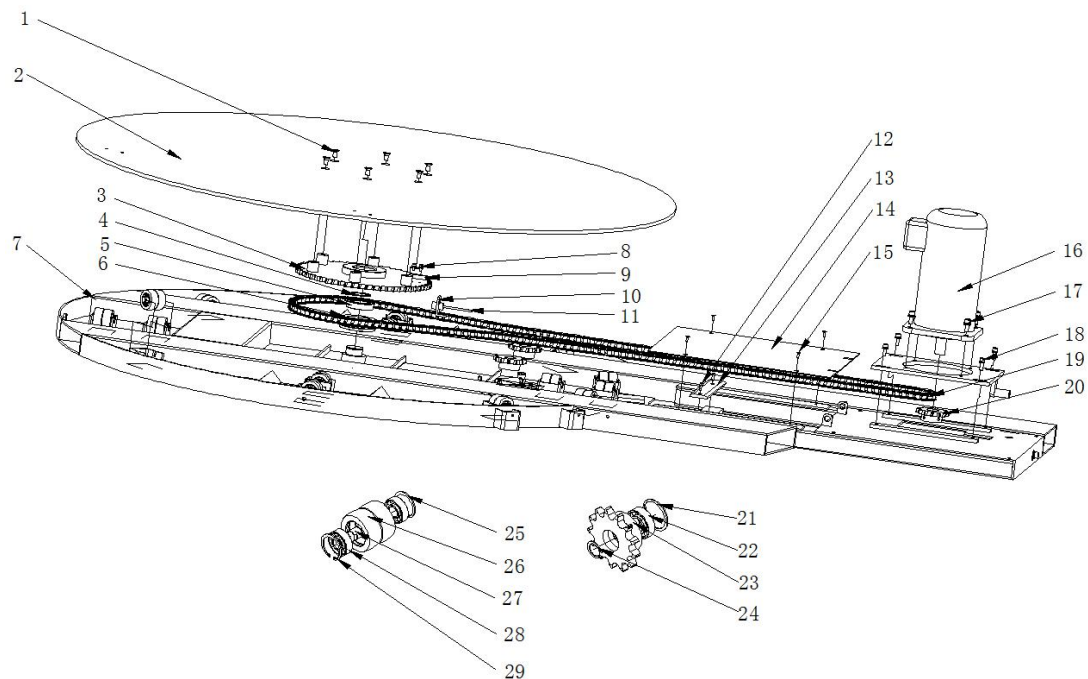

Serial no.	Part name	Drawing no.	no.
1	M10*25 head screw		6
2	turntable	916B-0201-N001	1
3	chain wheel	916B-0201-NA04	1
4	Rotation main axle clamp	916B-0201-N044	1
5	Rotation main shaft bearing	916B-0201-N046	1
6	Rotation main axle thrust bearing	916B-0201-N045	1
7	Chassis frame	916B-0201-NA02	1
8	M6*20 screw/Spring gasket/Flat gasket		2
9	Induction block	916B-0201-N024	1
10	Bracket	916B-0201-N029	1
11	sensors	916B-0201-N053	1
12	M5*15 screw		2
13	Spare chain tray	916B-0201-N042	1
14	The chain protects the lap	916B-0201-N059	1
15	M5*15 flat head screw		4
16	Gear motor	916B-0201-N055	1
17	M10*25 screw/Spring gasket/Flat gasket		4
18	M8*25 screw/Spring gasket/Flat gasket		4
19	Chain 12A	916B-0201-N056	1
20	Main Rotary sprocket	916B-0201-N040	1
21	Tightens the chain wheel inside caliper	916B-0201-N052	1
22	Tightens the chain wheel bearing	916B-0201-N051	1
23	Rotary sprocket	916B-0201-N041	1
24	Tightens the chain wheel outside caliper	916B-0201-N050	1
25	Bottom sprockets outside caliper	916B-0201-N048	1
26	Bottom sprockets	916B-0201-N038	2
27	Impeller Impeller	916B-0201-N039	1
28	Impeller bearing	916B-0201-N049	2
29	Impeller inside caliper	916B-0201-N047	2

5. Film carriage

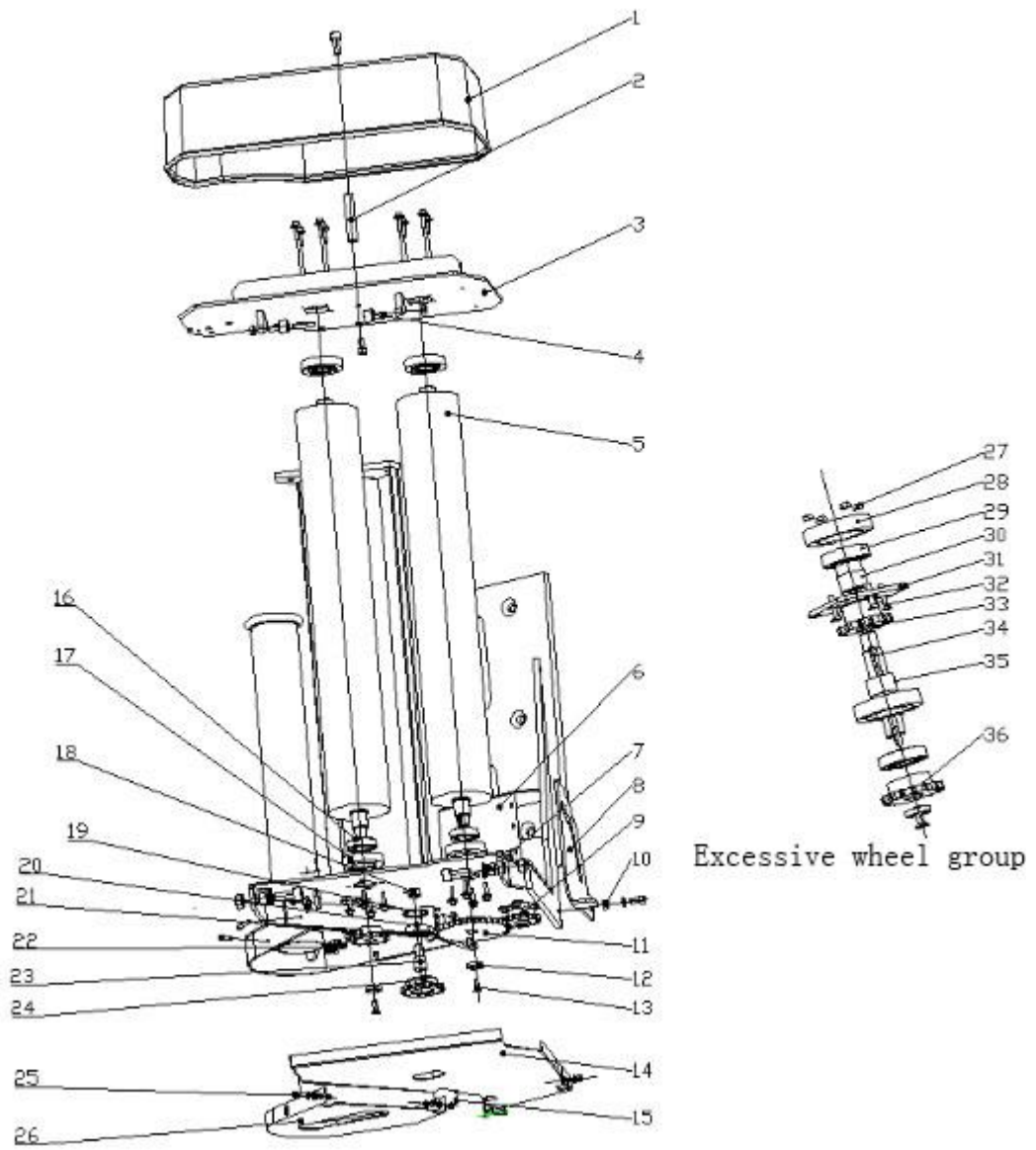

Serial no.	Part name	Drawing no.	no.
1	Mold shield	S022	1
2	Mold shield fixed column	S023	1
3	Mold shield fixing plate	SA04	1
4	Guide wheel	S039	2
5	Pulls the membrane drum	S048	2
6	Film frame transmission cover	S014	1
7	Membrane holder with steel bushing(Door pivot point)	S025	2
8	Open the door limit board	S024	1
9	Transition wheel group	SA15	2
10	Membrane holder with steel bushing(door limit board)	S025	2
11	Transmission driven sprocket	S051	1
12	pressing plate	S047	3
13	M5*16 flat head screw		3
14	Safety plate	S047	1
15	Safety plate torsional spring	S062	2
16	Bearing-61904		4
17	Pulls the membrane drum fixed stand	S046	4
18	Tightens the axle sleeve	S050	1
19	The hole uses the circlip (D=30mm)		1
20	Bearing -6200		1
21	Transmission drive sprocket	S044	1
22	Micro-switch D3M-01K2		2
23	tension shaft	S049	1
24	tension sprocket	S052	1
25	Safety board shaft sleeve	S065	2
26	Safety board 2	S058	1
27	M4 nut		24
28	Pulls the membrane drum fixed stand	S046	1
29	Bearing-61904		2
30	Transition shaft roof section	S045	1
31	mounting plate	S050	1
32	M4*20 flat head screw		4
33	Producing membrane driven sprocket	S042	1
34	Flat chain		2
35	Transition shaft main parts	S043	1
36	driven sprocket	S044	1

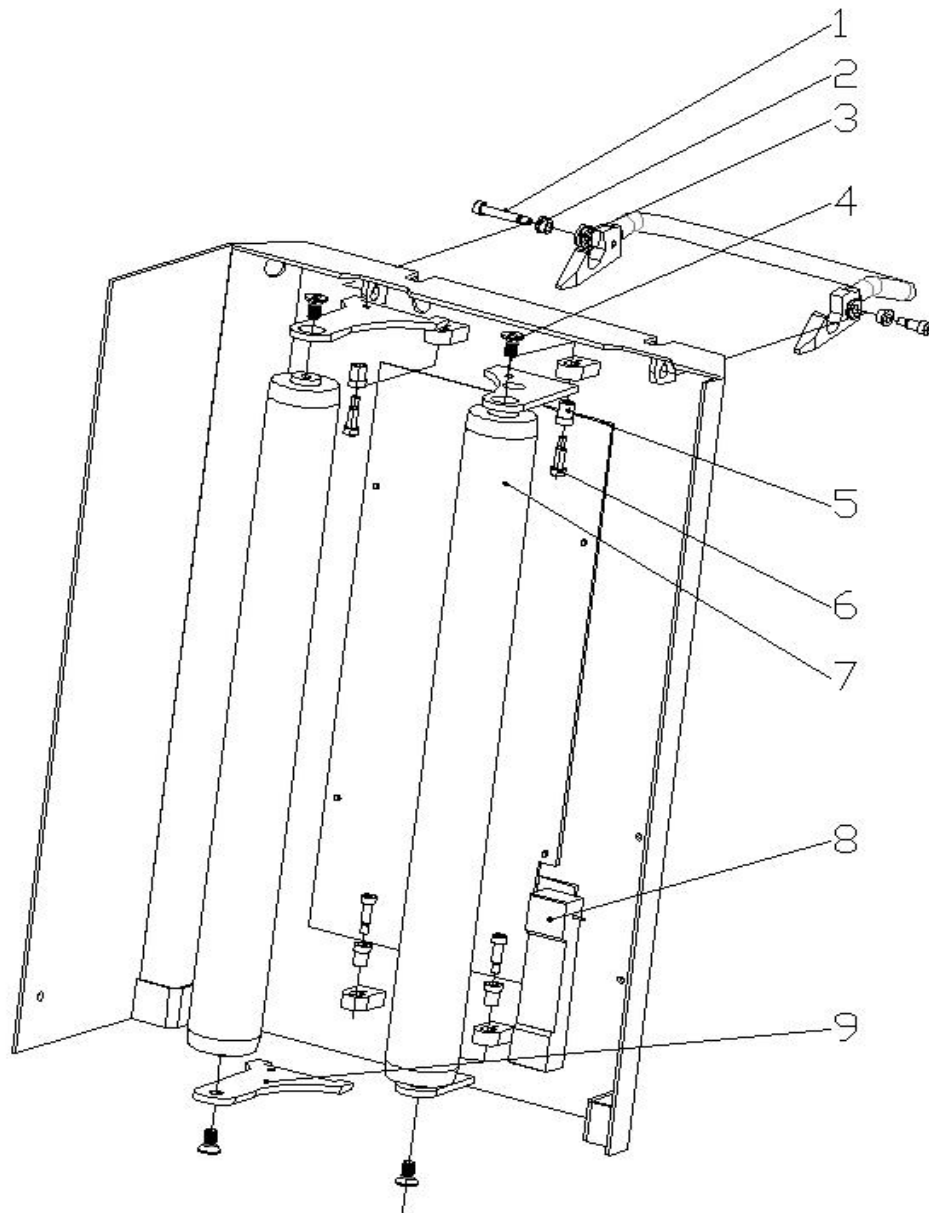

Serial no.	Part name	Drawing no.	no.
1	M5 Contour bolt	S140	1
2	Film carriage copper bushing(Hand left axis)	S025	1
3	Door handle reset spring	S038	1
4	M8*16 flat head bolt		4
5	neck bush	S25	4
6	M5-15 Contour bolt		4
7	No power roller installation	SA19	2
8	Pressure Sensor		1
9	Separating roller fixed piece	S034	1

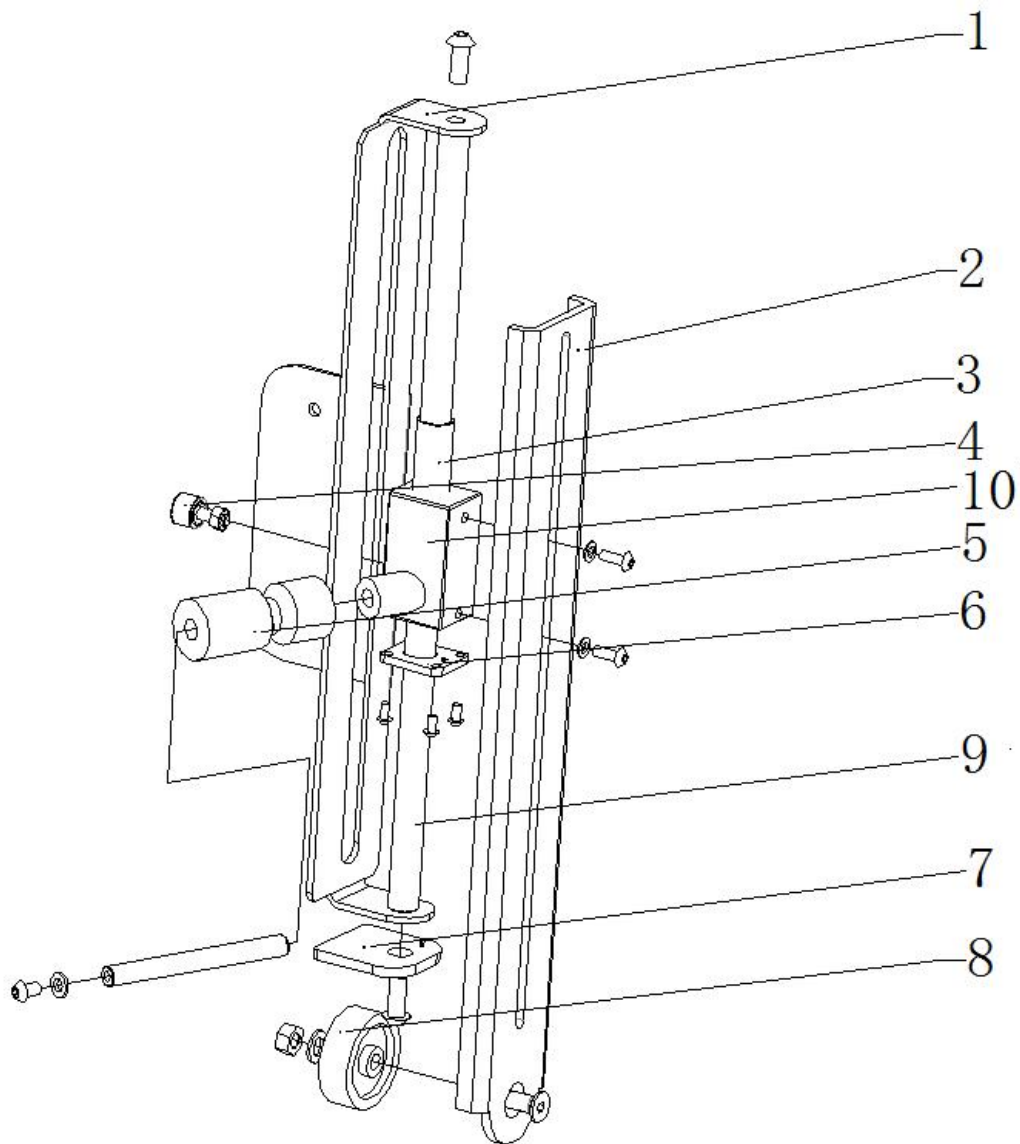

Serial no.	Part name	Drawing no.	no.
1	System rope Skeleton plate	916B-0201-R001	1
2	System rope power pole	916B-0201-R002	1
3	System rope guidance copper bushing	916B-0201-R009	1
4	With actuator	916B-0201-R012	1
5	Rope wheel device	916B-0201-R007	1
6	The system rope guidance body seals the head plate	916B-0201-R004	1
7	Process-wide rope plate	916B-0201-R003	1
8	Foma wheel	916B-0201-R011	1
9	Rope guide shaft	916B-0201-R005	1
10	Rope lifting	916B-0201-RA02	1

6. Electromagnet obstruct device

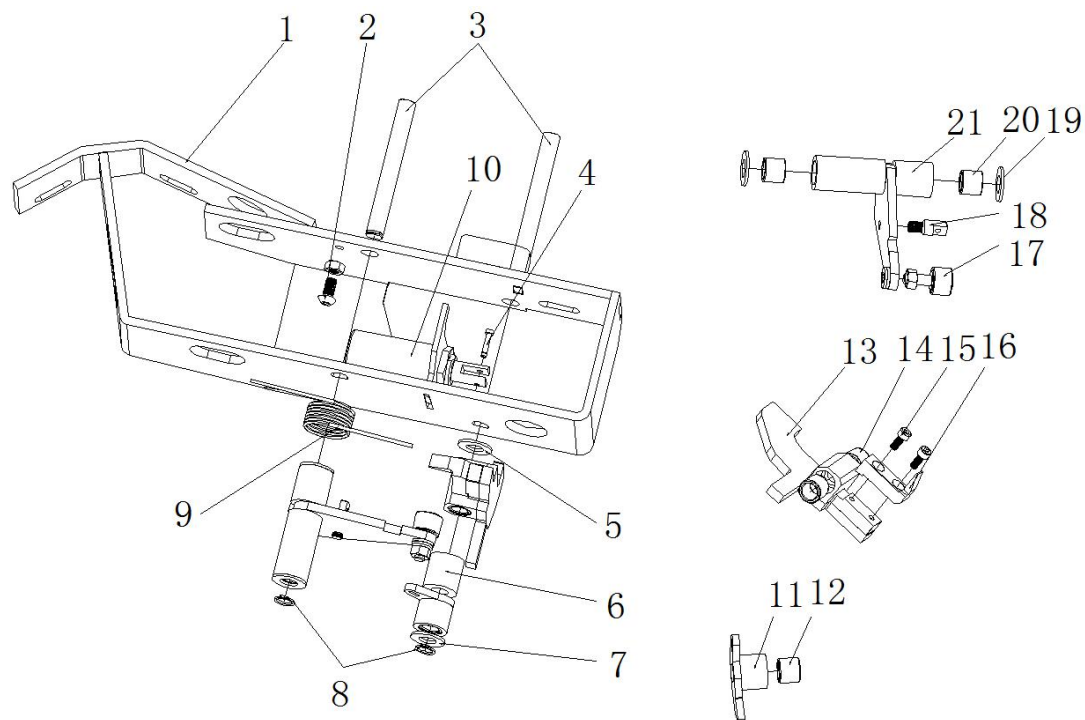

Serial no.	Part name	Drawing no.	no.
1	Assembly welding parts	916B-0201-AA02	1
2	M6-12 Round head screw nut		1
3	Install the transition plate	916B-0201-A005	2
4	Electromagnet connection point	916B-0201-A011	1
5	Traveling schedule control bushing	916B-0201-A007	1
6	assembly board	916B-0201-A009	1
7	Traveling schedule control bushing	916B-0201-A007	1
8	Circlip	916B-0201-A013	2
9	torsional spring	916B-0201-A016	1
10	Electromagnet	916B-0201-A015	1
11	lifting arm	916B-0201-A024	1
12	needle bearing	916B-0201-A024	1
13	Stop arm 2	916B-0201-A023	1
14	needle bearing	916B-0201-A024	2
15	M4-10 screws		2
16	Cam-connecting block	916B-0201-A008	1
17	Inverted CAM roller	916B-0201-010	1
18	M5 Contour screw		1
19	Traveling schedule control bushing	916B-0201-A007	2
20	needle bearing	916B-0201-A024	2
21	Stop arm 2	916B-0201-A022	1

7.cutting film system

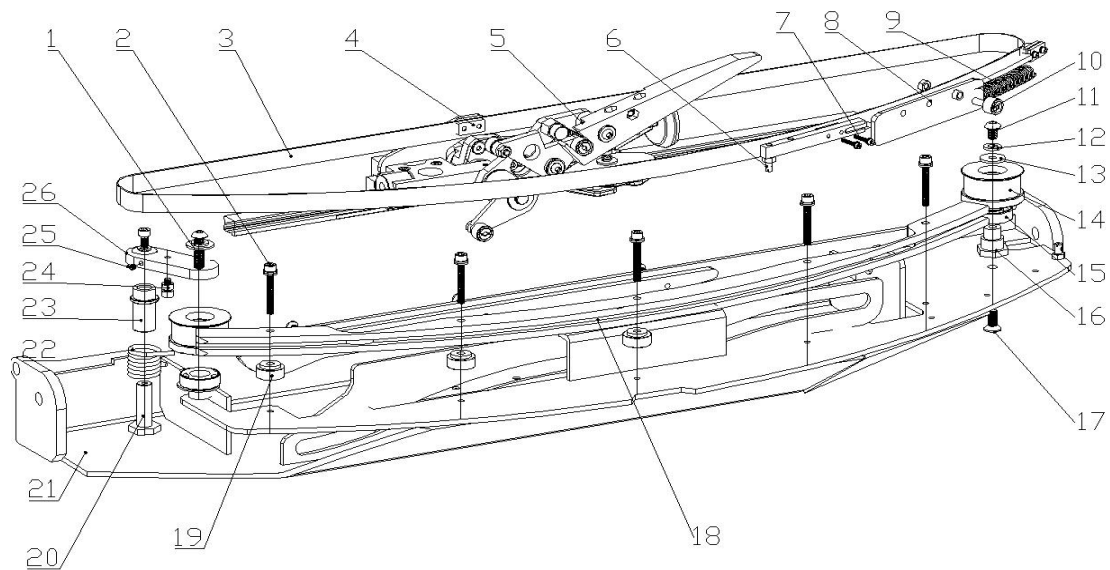

Serial no.	Part name	Drawing no.	no.
1	M8-35inner Hexagon socket head screws		1
2	M6-45 inner hexagon socket bolts		5
3	transformation leather belt	D010	1
4	Belt sheeting	D008	1
5	Cutting film device		1
6	spring strut 2	K004	2
7	M3-20 inner hexagon socket bolts		2
8	Belt Power frame	DA02	1
9	Reset tension spring	D011	1
10	CAM follower	D009	1
11	M8-12 inner hexagon socket bolts		1
12	M8- spring washer		2
13	Belt Pulley bearing pad	F002	2
14	Rotates the belt pulley	E001	2
15	belt pulley bearing	E007	2
16	Belt pulley installment axis	F001	1
17	M8-20 inner hexagon socket bolts		1
18	Belt chute	D001	1
19	Belt chute pulley	D002/D003	1
20	The belt tension wheel fixed axis	E004	1
21	Cutting film frame	CA01	1
22	Belt pulley torsional spring	E009	2
23	Belt fixed shaft	E003	1
24	Cutting film frame		2
25	M5-5 inner hexagon socket bolts		1
26	Tension Transition mounting plate	E002	1

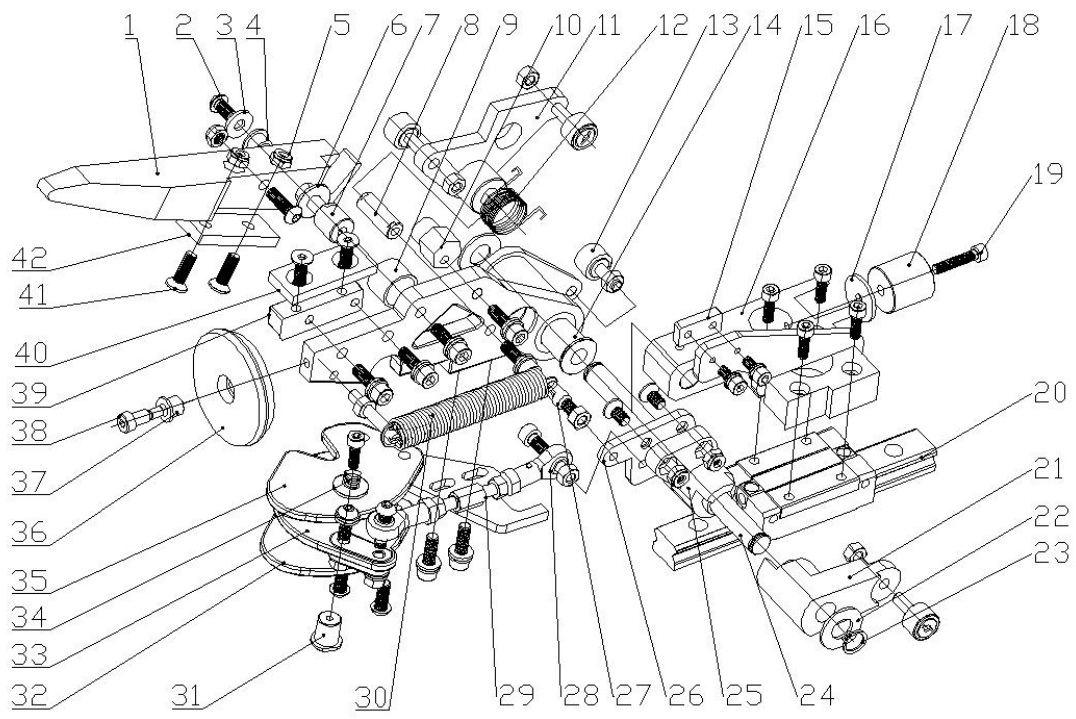

Serial no.	Part name	Drawing no.	no.
1	Activity blade supporting structure	G006	1
2	M6-12 round screw		4
3	Blade outer gasket	G005	3
4	knife rest Protective Steel cover	G004	1
5	M5 lock nut		5
6	Blade inner gasket	G003	1
7	Cutter on fixed shaft	G002	1
8	Activities knife revolution axis	G016	1
9	Blade open torsion spring	G020	1
10	Cutter adjusting shaft	G014	1
11	Power board	G015	1
12	Cutting knife reset torsion spring	G021	1
13	CAM roller		4
14	Cutter rotation axle sleeve	G019	1
15	drive shaft washer 1	J003	1
16	movable racks	J001	1
17	Base plate	J006	4
18	Pillar	J005	1
19	M5-25 Bolt		1
20	Wire rails	G008	1
21	Clamps the membrane movement arm	J008	1
22	drive shaft washer 2	J004	2
23	Initiative circlip1	J007	2
24	shaft	J002	1
25	Clamps the membrane driven axle sleeve	G007	1
26	shaft	K001	1
27	spring strut	K004	1
28	knuckle bearing	K005	2
29	knuckle bearing Connecting rod	K006	1
30	Puts the membrane extension spring	K007	1
31	rotating sleeve	L002	2
32	The bottom fixed plate	G010	1
33	active plate	G011	1
34	spring	L006	1
35	Upper fixing plate	G009	1
36	Leads the film wheel	M001	1
37	Leads the film wheel axle sleeve	M002	1
38	Fixed contour bolt	M003	1
39	Fixed blade frame	J013	1
40	Fixed blade	G013	1
41	M6-20 inner hexagon flat head screw		4
42	Activities blade	G012	1

5 Human computer interface

1.Starting page

Finger click on the screen to enter the automatic operation of the screen



2. automatic page

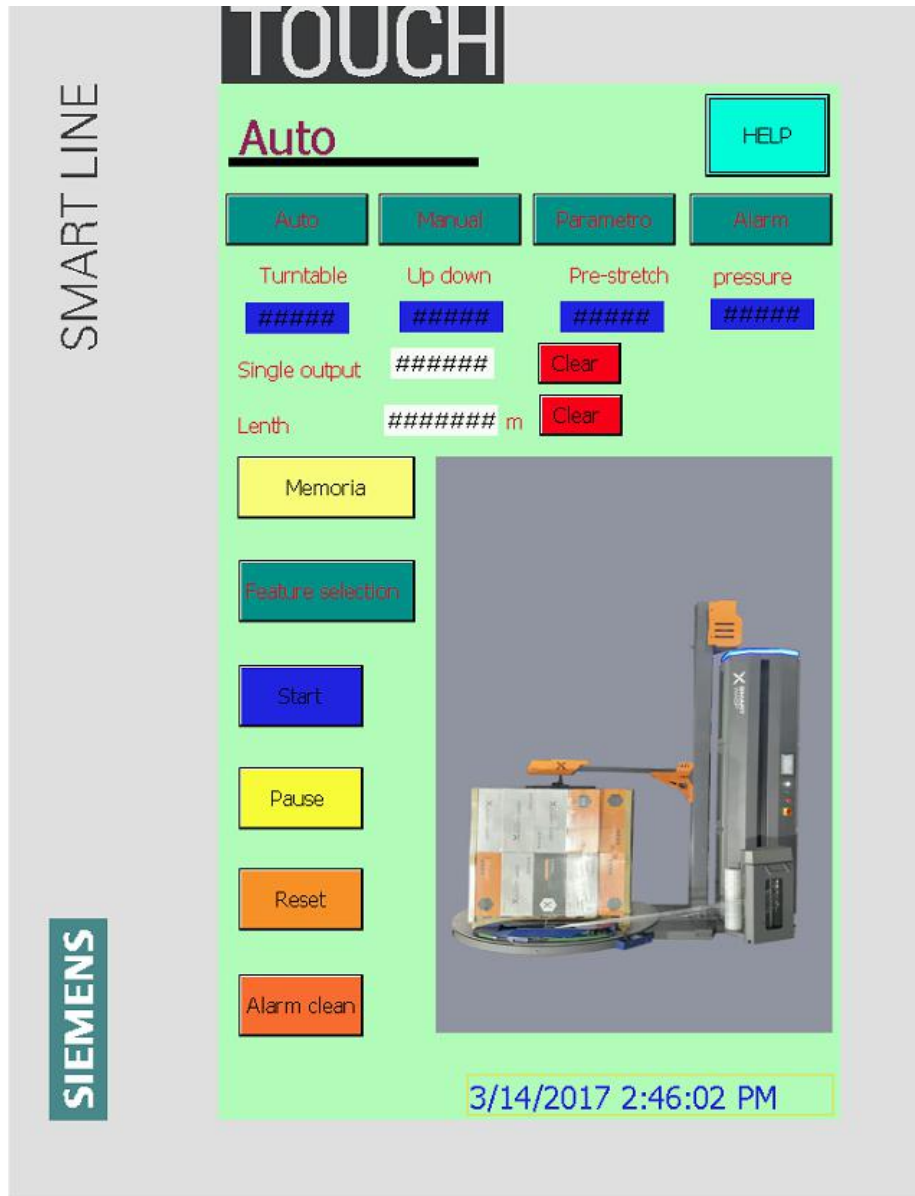

Help: click switch to help screen.

Turntable speed: used to set the chassis in the normal operation of the speed ratio, 100% - 0 corresponds to the frequency of 0 - 50Hz (the greater the percentage, the faster the speed).

Up down speed: used to set the speed ratio of the membrane seat lift, 100% - 0 corresponding to the frequency of 0 - 50Hz (the greater the percentage, the faster the lifting speed).

Pre-stetch rate : used to set the normal operation of the film seat put the proportion of elastic membrane (the larger the percentage, the film speed quick release, Mo Song is too tight easy directly pull off and not live clip, too loose may leads to incomplete film broken; general settings in 18%-40%, please according to the fine-tuning of the shape and size of the film toughness and pallet objects).

Pressure :the top pressure up and down speed

Length: the measure of the how many meter film have been used on pallet

Output cleared: click can be cleared of a single output.

Memoria: .6 wrapping model for different pallet ,need input data according to your self

Feather selection: single model ,choose film just go up and then stop ,or chose return ,film up and down and stop

Start: in the absence of any manual action, click to start winding machine automatically run.

Pause: click can make the current action in a paused state, once again, click continue to run, in both the automatic and manual can be used.

Reset: click the winding machine to immediately stop the current action, and then lift and chassis were reset to the initial position.

Alarm clear : click to cancel alarm

3. manual page

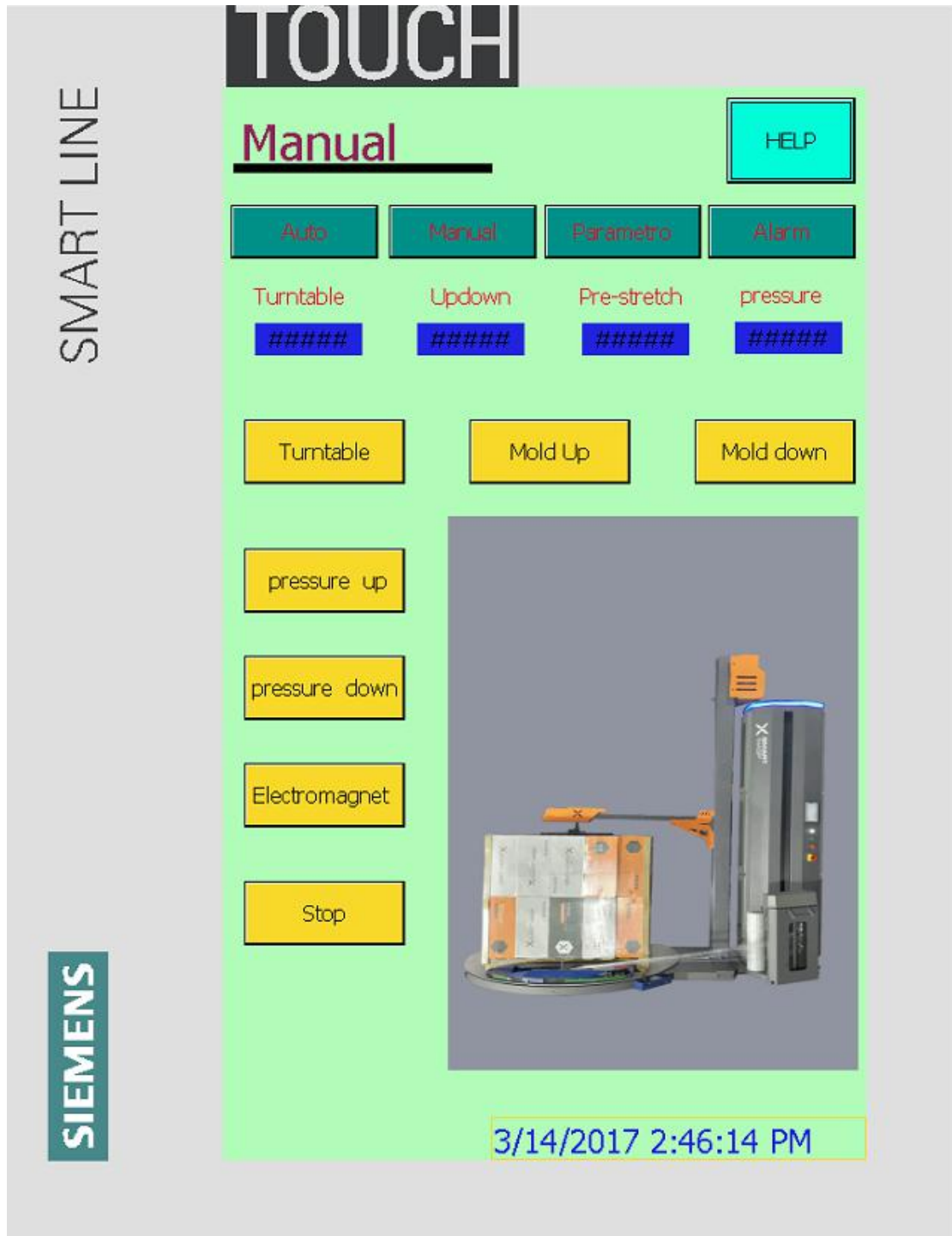

Help: click switch to help screen.

Turntable speed: used to set the chassis in the normal operation of the speed ratio, 100% - 0 corresponds to the frequency of 0 - 50Hz (the greater the percentage, the faster the speed).

Up down speed: used to set the speed ratio of the membrane seat lift, 100% - 0 corresponding to the frequency of 0 - 50Hz (the greater the percentage, the faster the lifting speed).

Pre-stetch rate : used to set the normal operation of the film seat put the proportion of elastic membrane (the larger the percentage, the film speed quick release, Mo Song is too tight easy directly pull off and not live clip, too loose may leads to incomplete film broken; general settings in 18%-40%, please according to the fine-tuning of the shape and size of the film toughness and pallet objects.

Turntable: when you are not in a state of automatic operation, click the turntable to rotate, and once again, the turntable stops.

Mold up: in the state of the automatic operation, click the film rise, again click the film seat to stop rising, when the film seat to reach the upper limit of the film seat also stopped rising.

Mold down: in the state of the automatic running, click the film seat down, again click the film to stop the decline, when the film seat to reach the lower limit of the film seat also stopped falling.

Pressure Up :top pressure device go up

Pressure Down:top pressure device go down

Electromagnet: not in state of automatic operation, click the electromagnet pop-up again click electromagnet stop electricity electromagnet need external force will be retracted.

Alarm clear : click to cancel alarm

4. parameter settings page

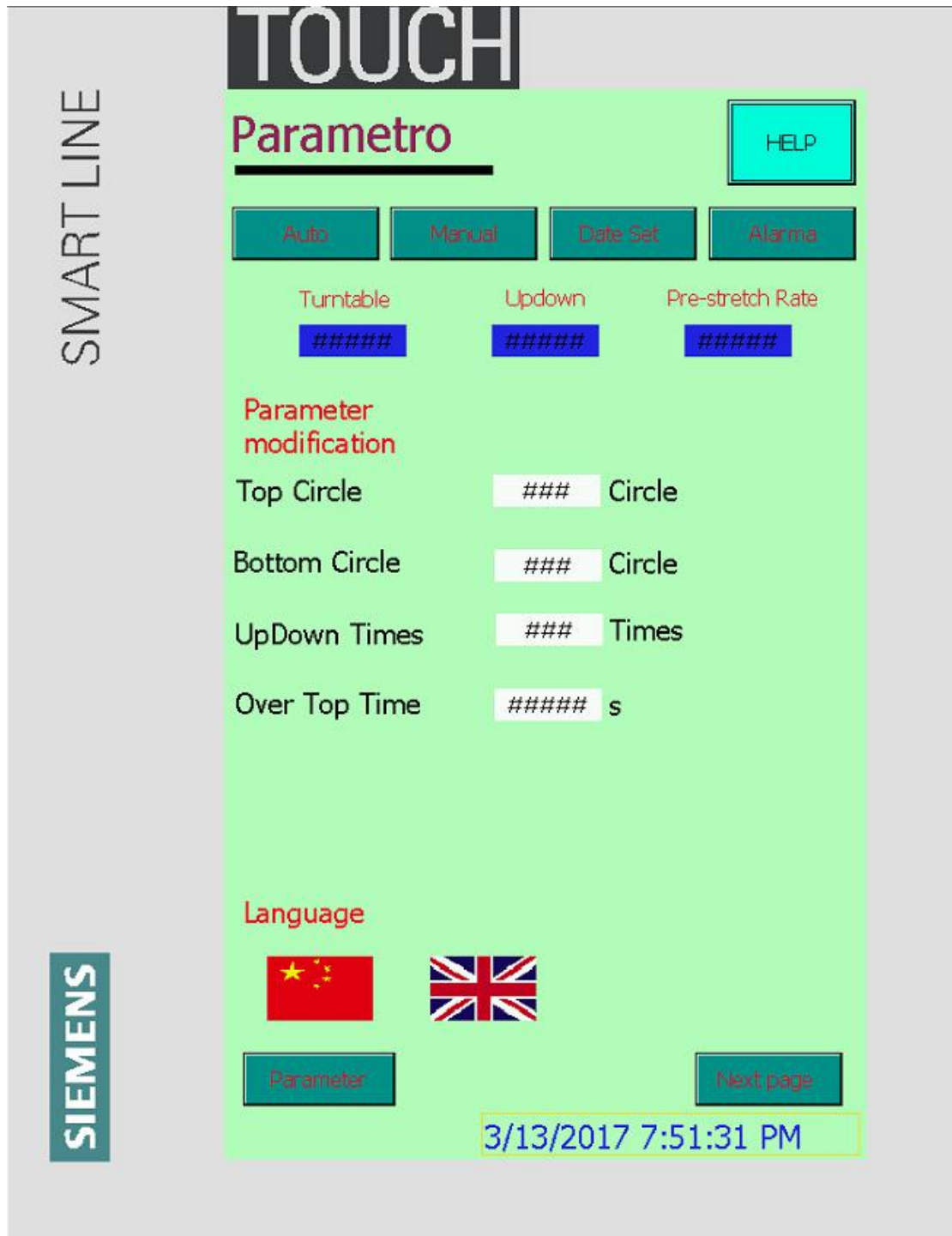

Help: click switch to help screen.

Turntable speed: used to set the chasis in the normal operation of the speed ratio, 100% - 0 corresponds to the frequency of 0 - 50Hz (the greater the percentage, the faster the speed).

Up down speed: used to set the speed ratio of the membrane seat lift, 100% - 0 corresponding to the frequency of 0 - 50Hz (the greater the percentage, the faster the lifting speed).

Pre-stetch rate : used to set the normal operation of the film seat put the proportion of elastic membrane (the larger the percentage, the film speed quick release, Mo Song is too tight easy directly pull off and not live clip, too loose may leads to incomplete film broken; general settings in 18%-40%, please according to the fine-tuning of the shape and size of the film toughness and pallet objects.

Top Circle: used to set the top to strengthen the number of rings, the film will rise to the height of the product after the stop, until the completion of the top to strengthen the number of laps before falling

Bottom circle : used to set the number of rings to enhance the bottom, the film will stay at the bottom until the completion of the bottom to strengthen the number of laps and then carry out other actions.

Up and down times: used to set the film seat lifting round-trip times, set for a round trip, set to 2 to travel between the two, and so on.

Over top time: used to set the time when the film rises to the height of the product (photoelectric sensor less than the product) continues to rise.

System parameters: click the system parameters of the device.

The next page: click switch to the next screen.

Chinese: Click to switch the language to Chinese.

English: Click to switch the language to English.

4.1system parameter page

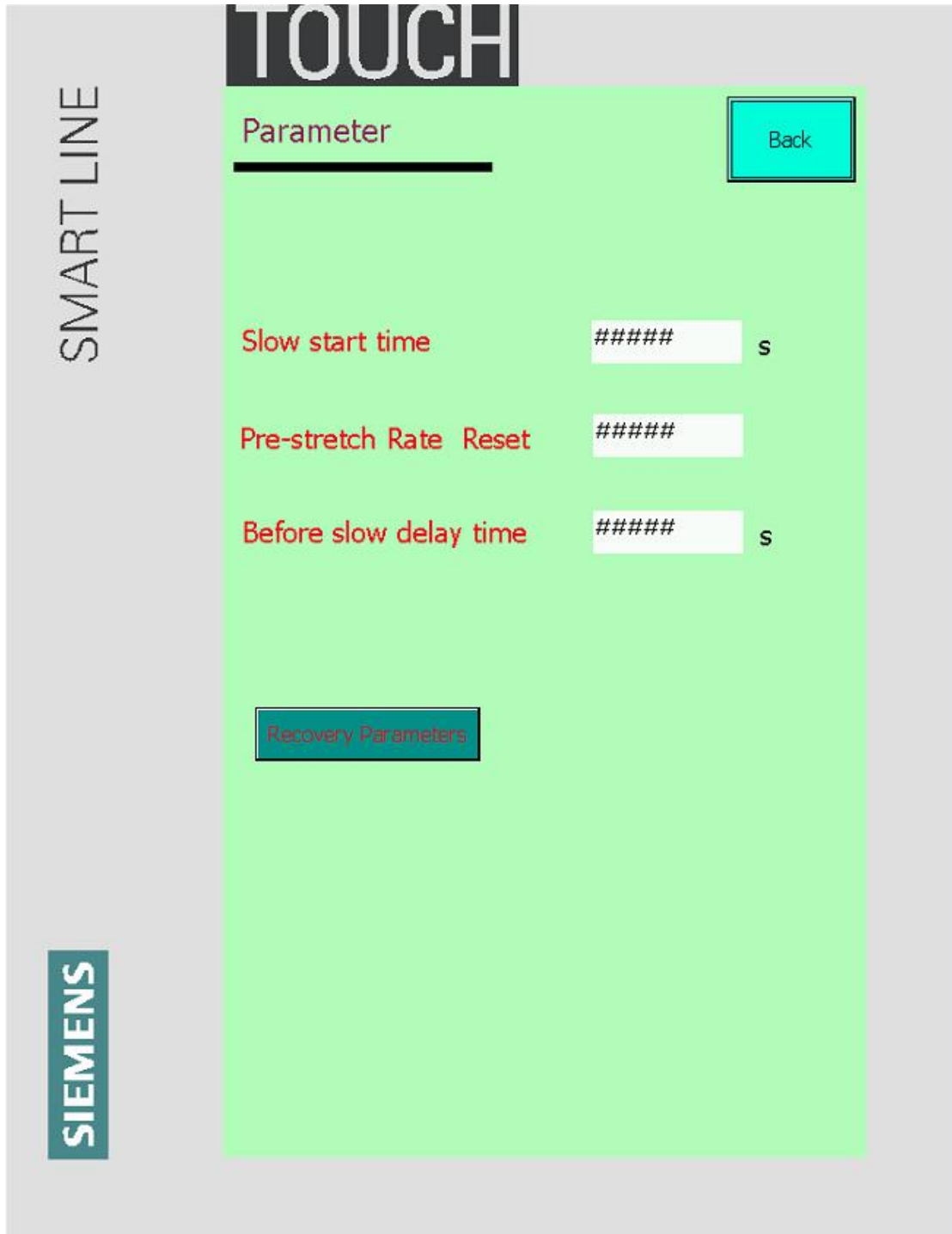

Slow start time: for setting the chassis from the static to start to the normal operation of the speed of the time (the shorter the time set, the disc starts to pull the film larger).

Pre-stretch rate reset :used to set the chassis to enter the broken film to stop the speed (speed control, directly related to the initial position of the turntable accuracy; generally set between 20%~25%, set up after the customers do not easily change)

Before slow delay time: it;s at the end of circle ,the slow speed setting

4.2 I/O monitor page

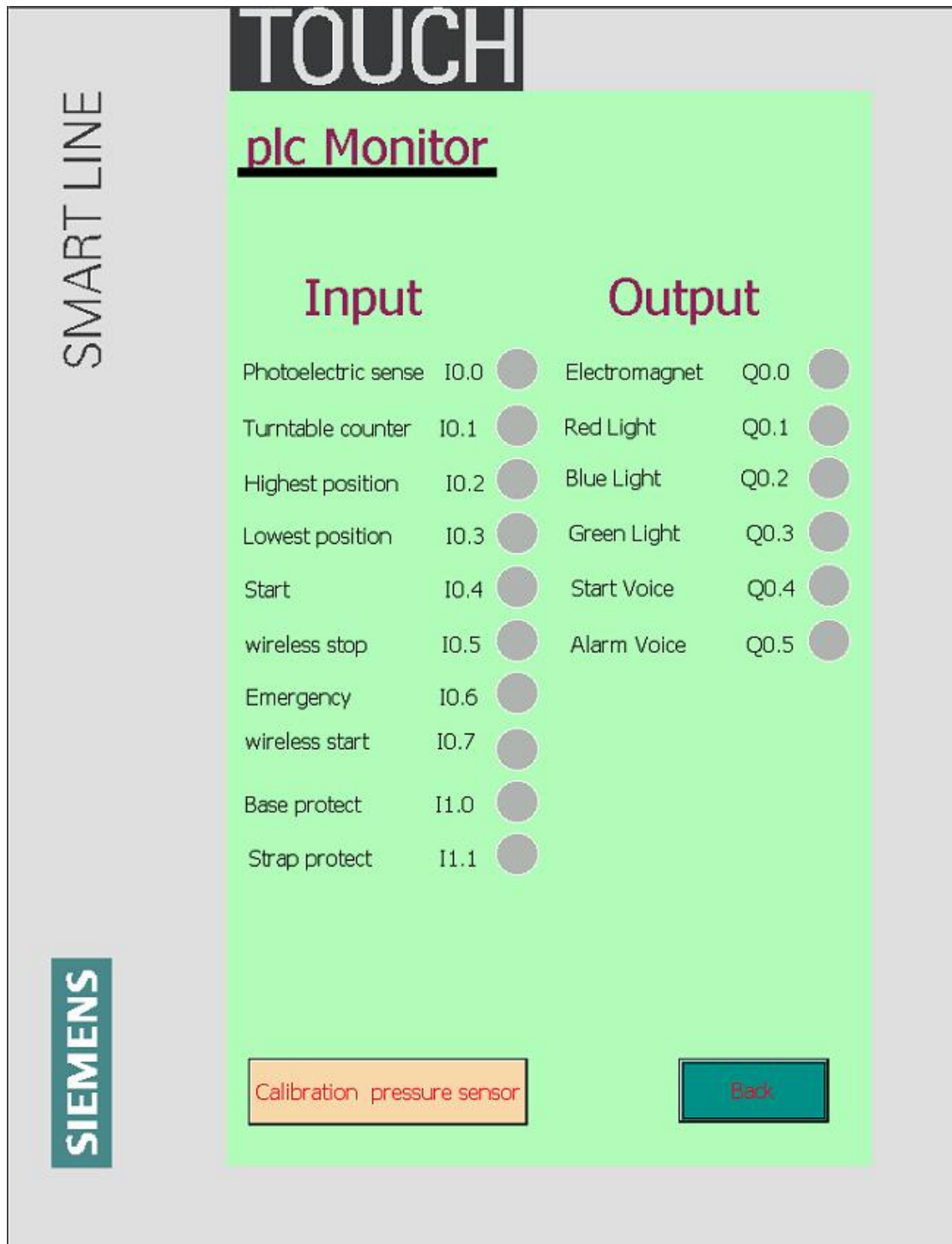

Automatic screen: click switch to automatically operate the picture.

Manual screen: Click to switch to manual operation.

Set the screen: display the current picture as the parameter settings screen.

Alarm screen: click switch to the alarm view screen.

Help: click switch to help screen.

PLC terminal monitoring: display the real-time motion of the PLC on the situation.

On a page: click switch to the top of a picture.

5 .help page

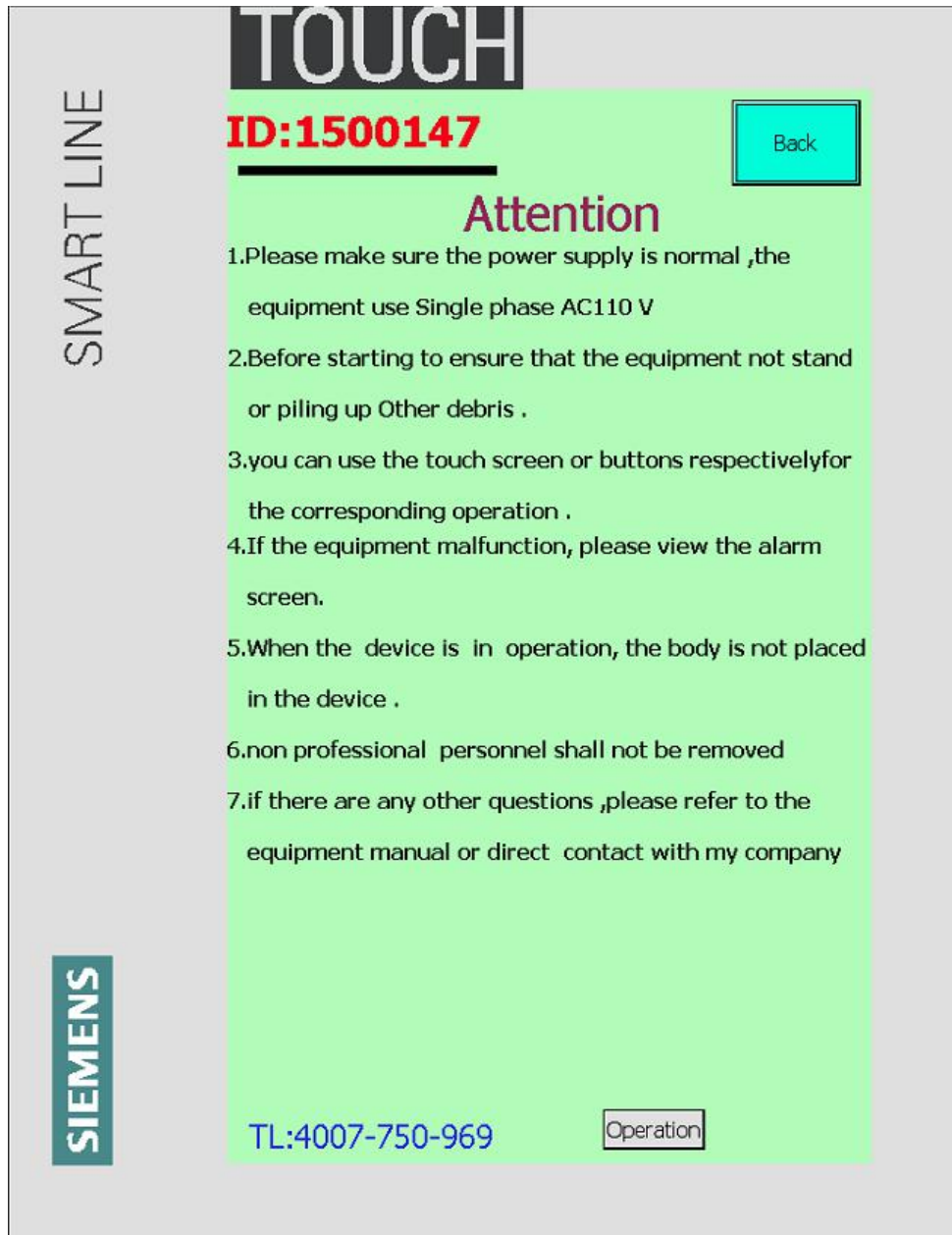

Displays help information for the device.

Returns: Click to return to the previous screen.

ID: display the device number for this device.

6 Operating procedures

1.starting up

Turn the power switch to ON and click on the start screen to enter the operation screen.

2.Mounting film

2.1 install membrane preparation

- A. Take up wrapping film rolls, and identified as the machine pre-stretch PE membrane
- B. to confirm the direction of the placement of the film according to picture below (in the direction of downward observation)

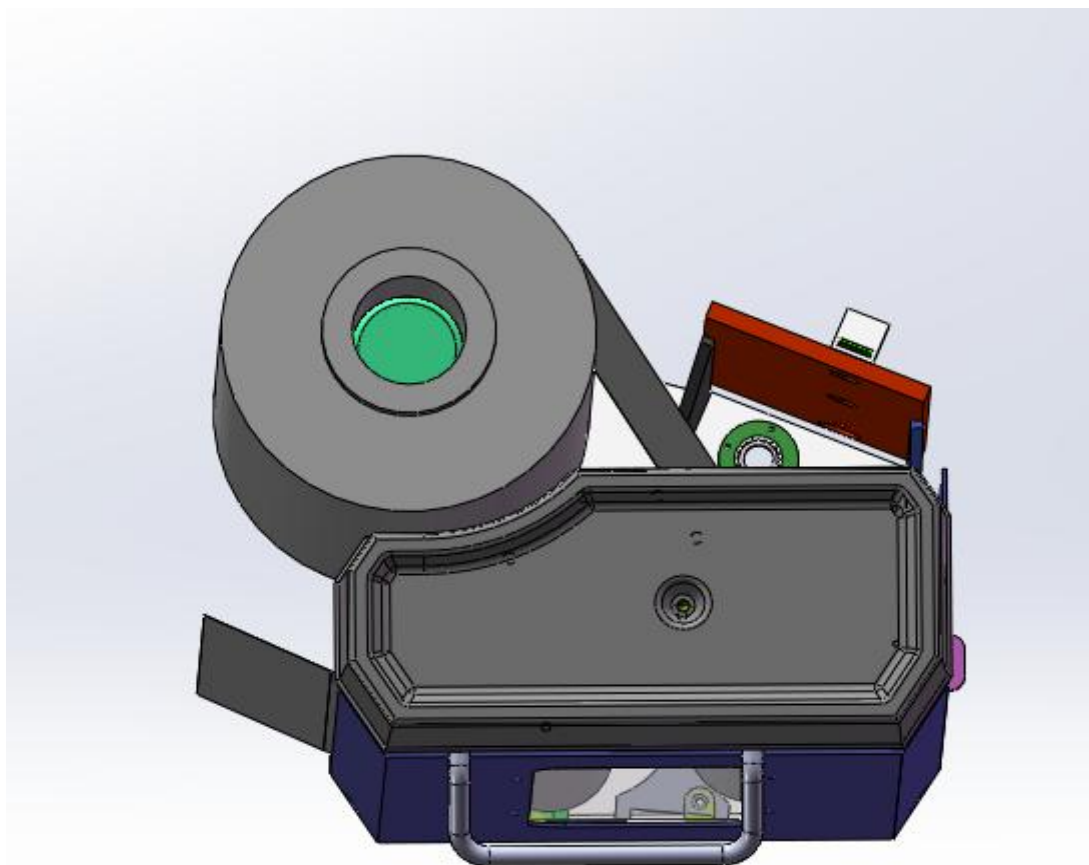

- C. confirm that the film carriage is in the initial position, (and had better to turn off the power when the time allowed.)

2.2 install film

- A. pull the membrane door handle with the hand to open the membrane door
- B. the film roll head pulled about 50-60cm length, and then set to the correct direction of the film roll (see photo)

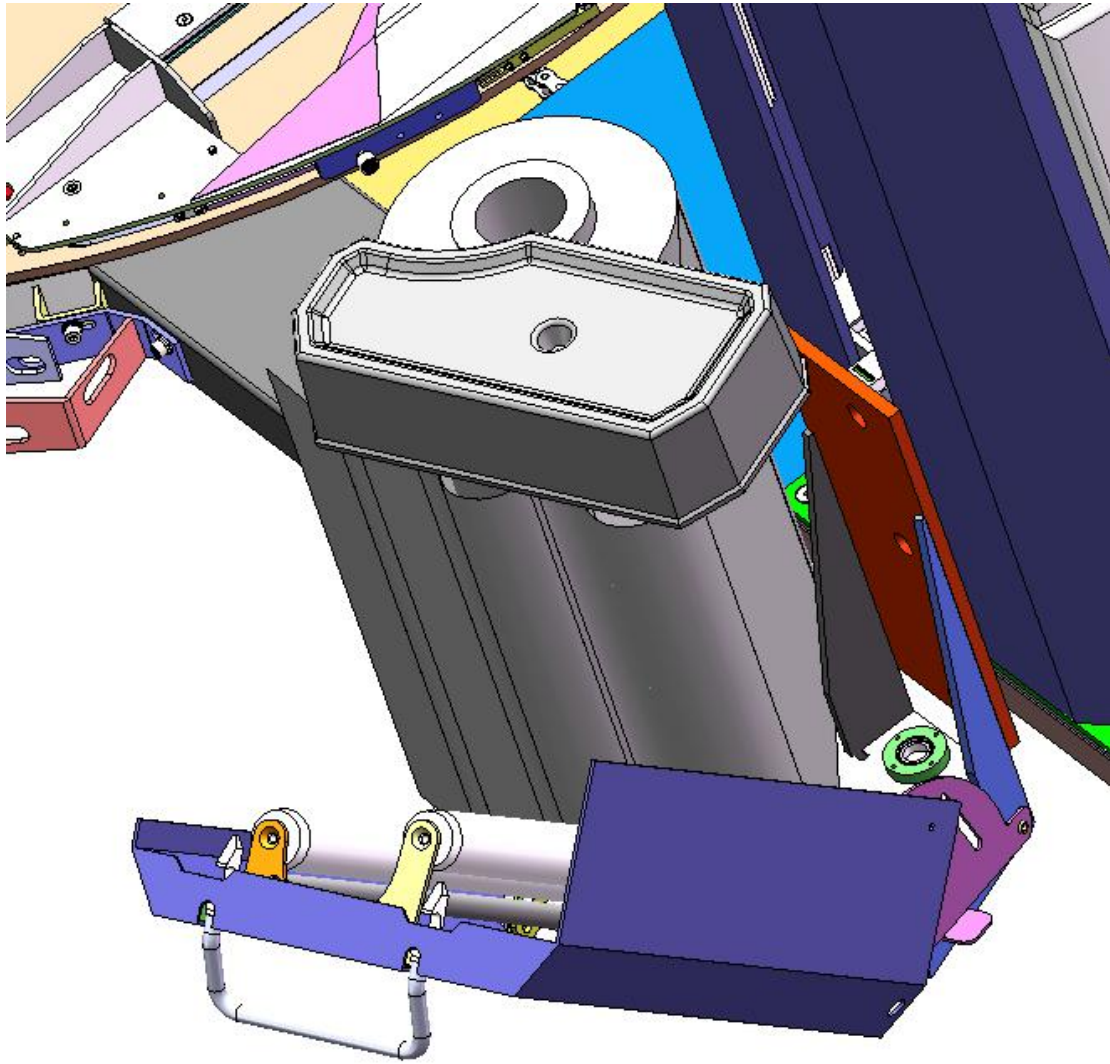

- C. the film coil head is elongated and wrapped around the film seat 3/4 volume in the direction of the icon and the direction of the turntable
- D. closes the membrane door body
- E. film head is fixedly connected with the bottom of the product pallet



watch out!:

1. Close the door shut the door body wrap at relaxation can reduce shut
2. In the process, we should avoid the human body contact with the membrane seat of the moving parts
3. After the door body is closed, it is best to use the hand to press down the handle to confirm that the door is closed.

7 Common breakdown and elimination

1. indicator light doesn't work

- 1.1 power not open: open power
- 1.2 power not inserted: plug in
- 1.3 indicating lamp is bad: change indicator light

2. turntable doesn't work

- 2.1 power is not connected or missing: check power supply
- 2.2 chain break or fall off: to re-install the chain and confirm the tension chain, the tension after the confirmation of tension screw fixation, no loosening.
- 2.3 frequency converter regulating knob to adjust the minimum position: adjust to a reasonable position (non - technical personnel to prohibit the random adjustment of equipment parameters and equipment on some variables set)
- 2.4 emergency stop switch in the stop position: open the emergency stop switch.
- 2.5 whether control button is invalid: confirm, if the connection is loose because of the connection line to re fixed. If the button itself is damaged, the need to replace the button.

3. lifting device doesn't work

- 3.1 emergency stop switch in the stop bit: open the emergency stop switch
- 3.2 frequency converter regulating knob to adjust the minimum position: adjust to a reasonable position (non - technical personnel to prohibit the random adjustment of equipment parameters and equipment on some variables set)
- 3.3 power is not connected or missing: check power supply
- 3.4 limit switch or turntable count sensor failure to confirm whether the switch or

sensor is loose, if the position is correct, if the position is correct and no loose. confirm the switch or sensor is damaged, if there is damage to the replacement.

3.5 chain rupture or stuck: to confirm whether there is a foreign body involved in the chain, the chain tension to relax, to re install the chain, adjust the tension.

4.stretch film is pulled off

4.1 winding film has a fracture or poor quality: replacement of the winding film.

4.2 Pre-stretch chain off or sprocket loose; re-install the chain or tighten the sprocket.

4.3 pre-tension motor speed and motor speed, no turntable: adjusting the speed of both good, which match.

5.Electromagnet obstruct device doesn't work

5.1 obstruct can't normal bounce; confirm that whether the obstruct quick and connection quick plug is loose, Not plugged in.

5.2 obstruct can't normal bounce; Human Machine Interface, click the electromagnet magnet, confirm that whether electromagnet can work normally, if not,then replace the electromagnet.

6.cutting film system doesn't work

6.1 film can not be cut off

The rope height is too high, adjust the rope height to the appropriate position. confirm that whether the compression spring screw is loose, if there is loose, tighten then.

6.2 film can't be griped

Chassis speed is too fast, adjust slowly the speed

6.3 film is pulled off:

Confirm the quality of the same batch of film, replace the winding film.

8 Equipment safety precautions

1. confirm the power of the machine, the machine uses a single-phase AC220V. dual color line for the ground wire.

2. when the machine is running, it is strictly prohibited to pedal on the machine.

3. the installation of the machine can not be installed on the soft ground.

4.prohibit the need to wrap objects placed on the edge of the turntable.

5.in case of emergency, press the emergency stop switch and power off the machine.

6. after the completion of the work, should clean the machine once.

7.non professional personnel, can not be arbitrarily open electrical equipment.

9 Circuit diagram

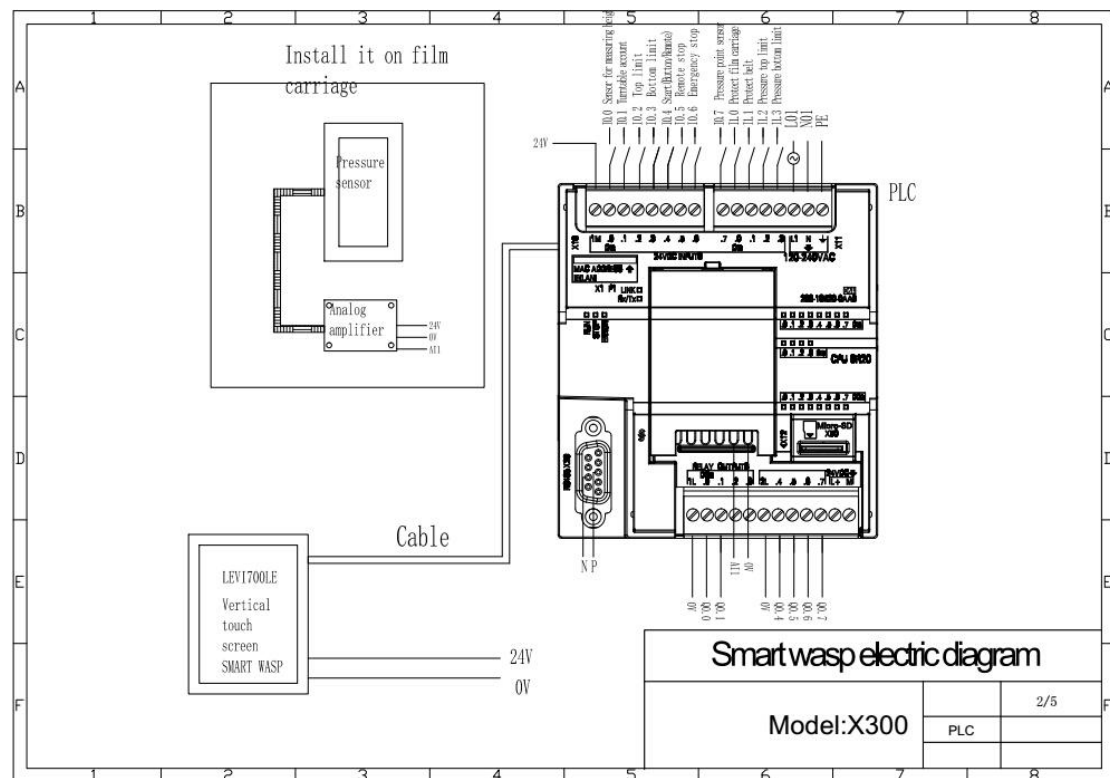
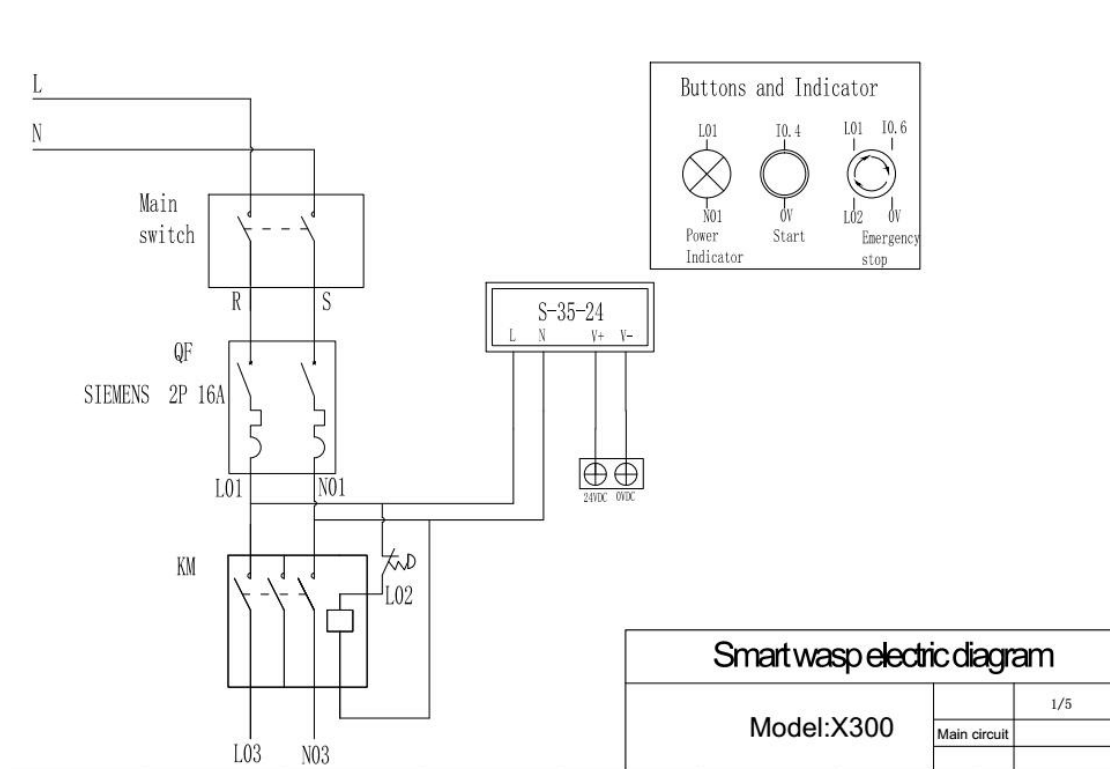

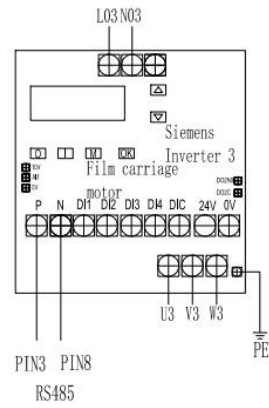
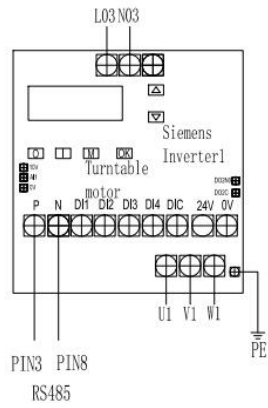

Smart wasp electric diagram

Model: X300	3/5
Inverter	

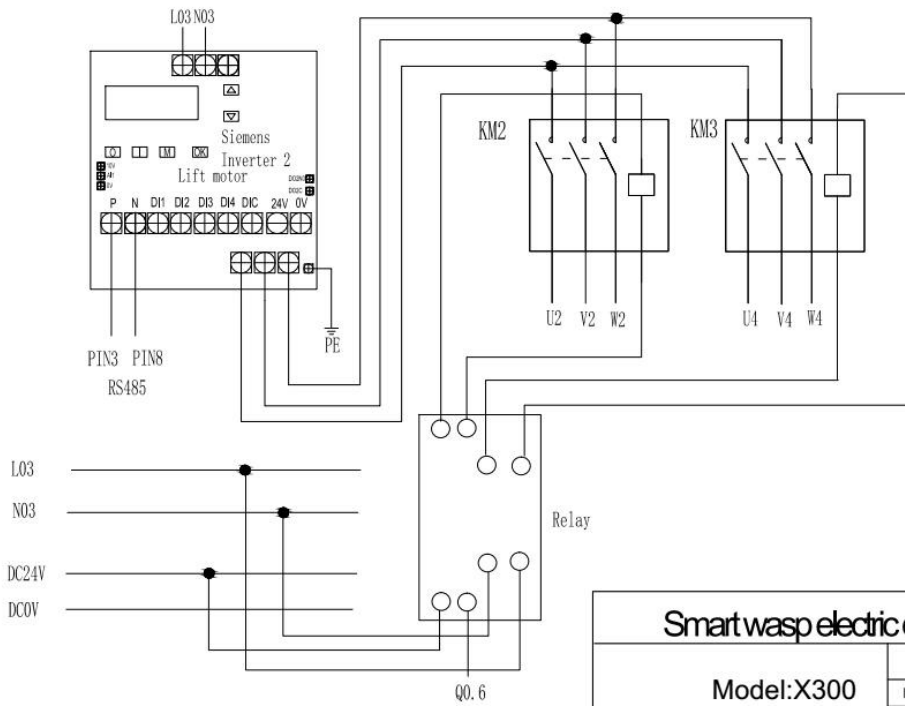

Smart wasp electric diagram

Model: X300	4/5
Inverter	

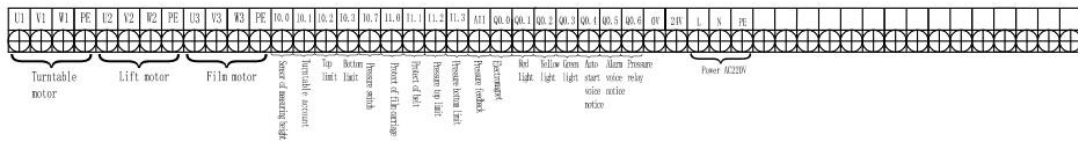

Smartwasp electric diagram		
Model:X300		5/5
	Terminal row	

10 care and maintenance

Regular equipment maintenance and maintenance, not only can extend its service life, but also can be less trouble, so as to improve production efficiency. Maintenance and maintenance of equipment is strictly prohibited two or more people at the same time the operation of the machine.

1. preparation before maintenance

- 1.1 maintenance workers do safety protection, safety Quanfeng, safety shoes, gloves.
- 1.2 ensure that the power supply is cut off before maintenance

2. maintenance points

- 2.1 regular inspection of parts screws is loose
- 2.2 regular oil on the important parts of the machine.
- 2.3 keep the machine clean and tidy.

3.key maintenance instructions

3.1 open between the turntable and the upright post cover, chassis chain apply to the amount of lubricating oil, in the man-machine interface manually according to the rotation of the turntable, to the whole chain of oil. (recommended every three months on an oil)

Open the cover to the chain chain oil

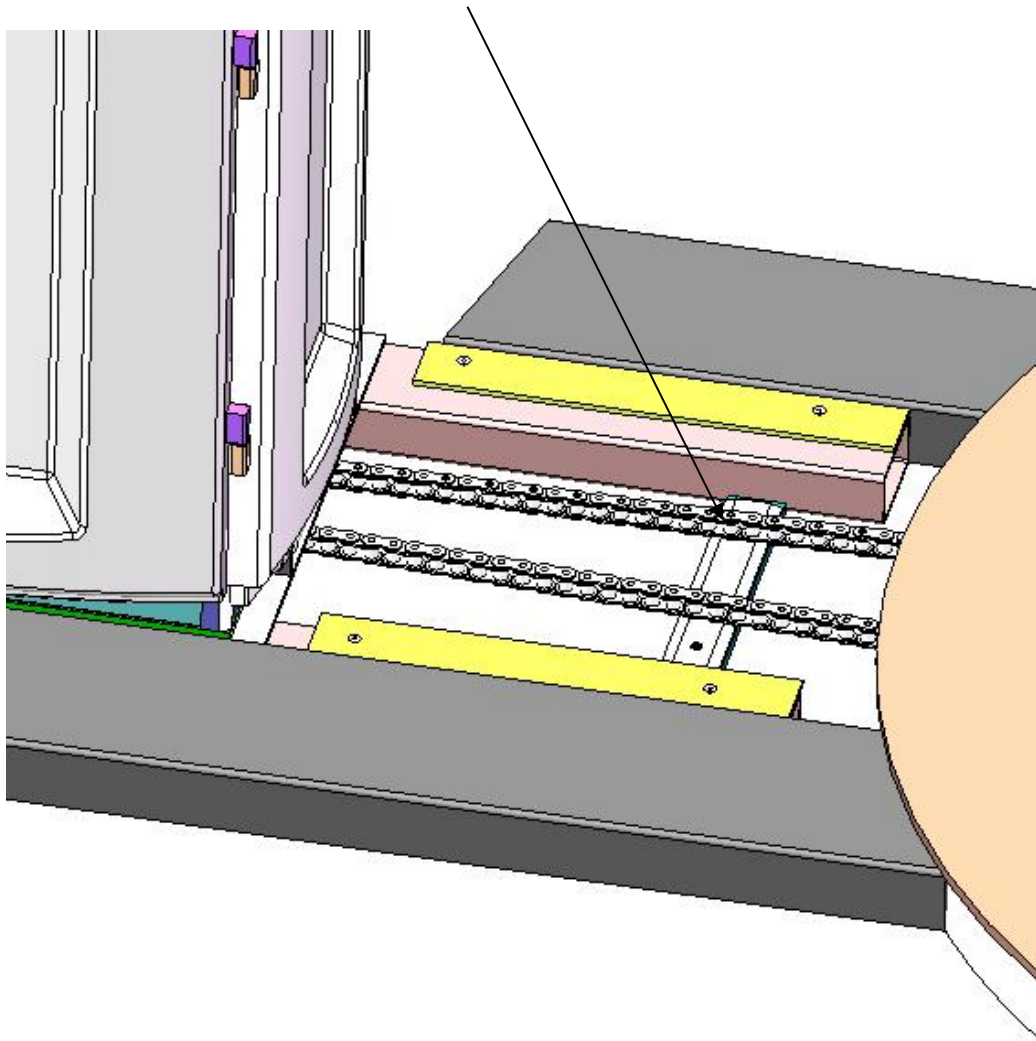

3.2 the lifting body rises, to open the side door mold base chain oil (recommended every three months on a)

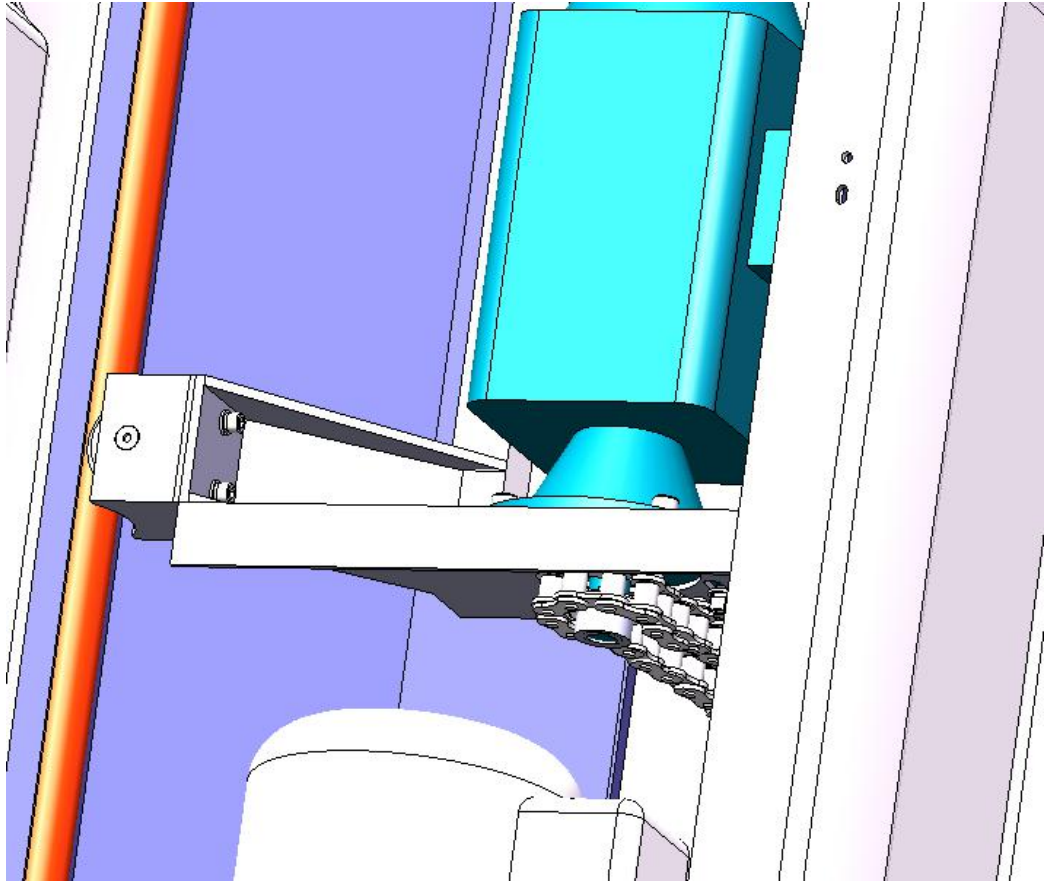

9.safety device

1.Feet &head protect system

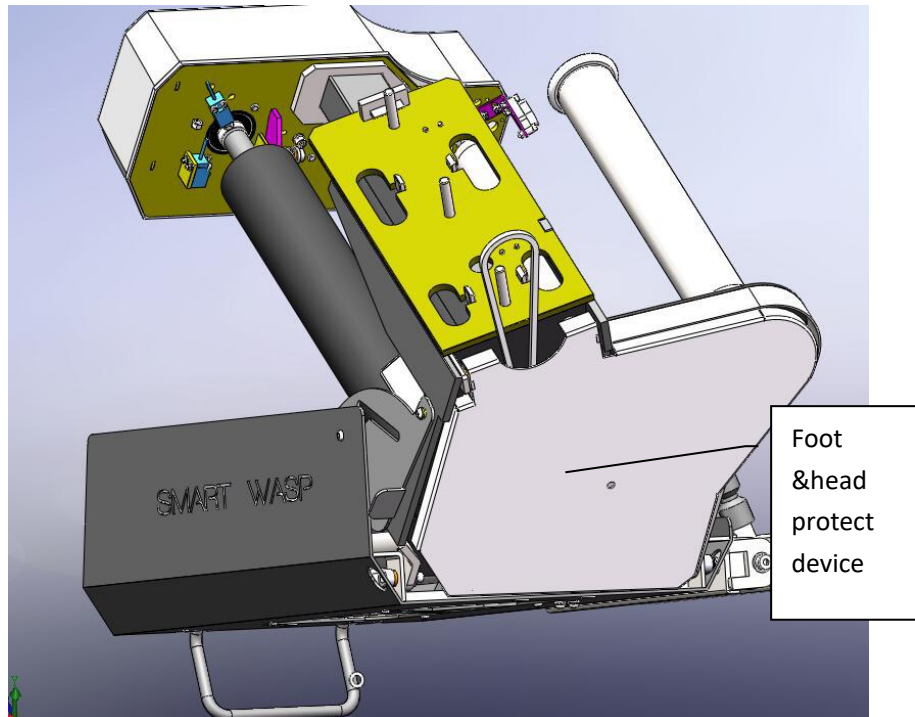

Picture 3.1.5-1

Foot and head protect system is main for protect the operator safety ,if the film carriage go up over the operator head , if the operator in under the film carriage during the carriage do down ,if the film carriage touch the head of the operator ,the machine will stop work immediately and LED light will alarm at same time so that avoid the film carriage hurt the operator head , the film go down to to floor ,if the operator feet in under the potion of the film carriage ,when the film carriage touch the foot of the operator ,the film carriage will stop go down immediately and the LED light will alarm .in this way ,the film carriage will not hurt the operator 's foot. See picture 3.1.5-1

2.Open door safety system

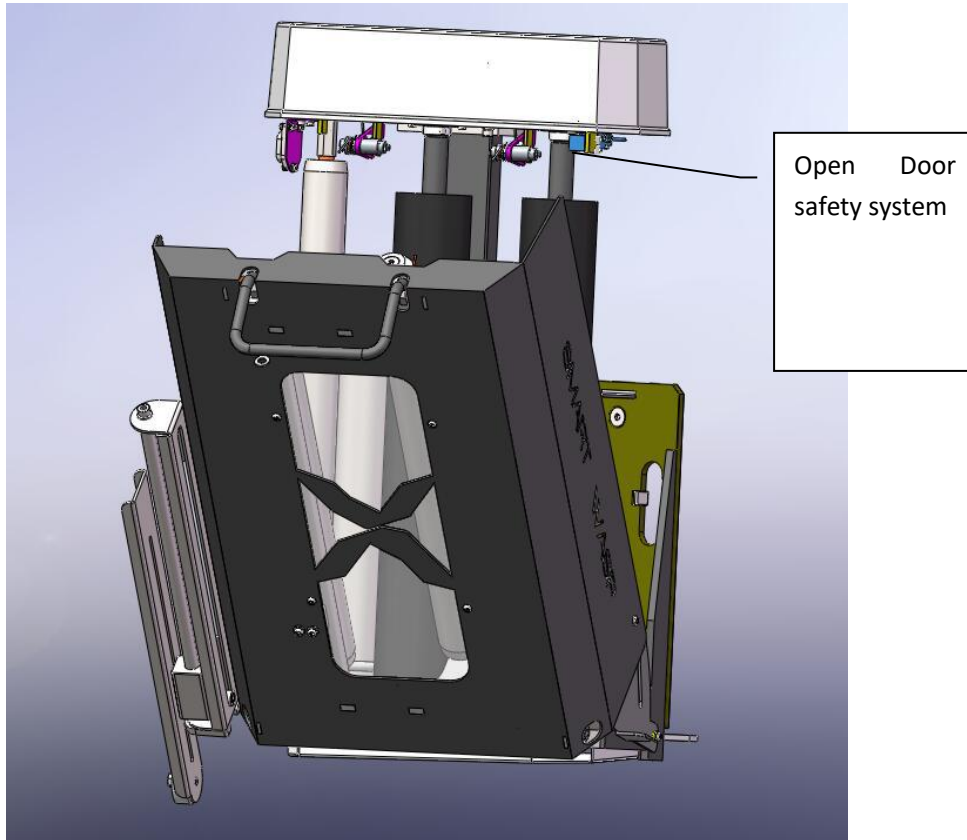

3.1.5-2

Open door safety system is main for the safety of operator when replace new film or open door to fix machine ,after the operator open the door ,the machine will stop work ,and the machine can not start any more ,just when the operator close the door again and then can let the machine run again. See picture

3. Film carriage Anti dropping system

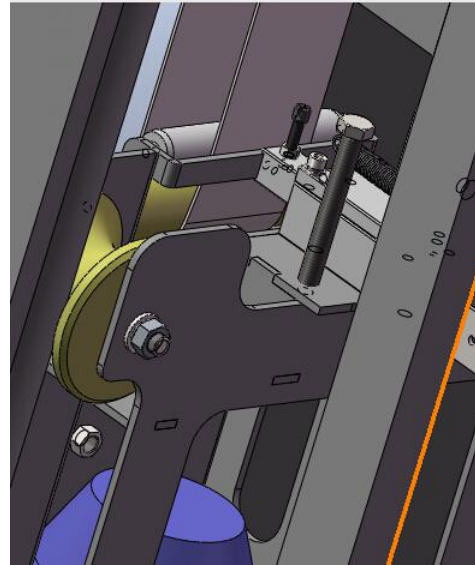
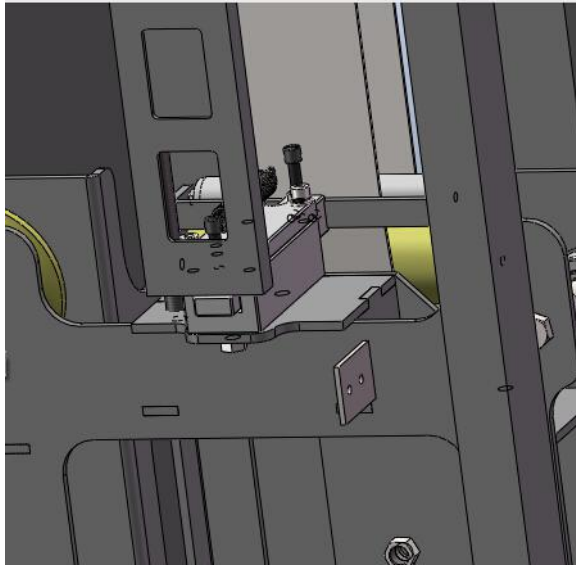

Film carriage Anti dropping system(safety device) : if the drive belt loose or break, the anti dropping system will work immediately and lock the film carriage so that stop the film carriage fall down , in this way , if have worker under film carriage ,this system will protect the worker do not get hurt. See picture

10.Attached: Equipment Checklist

1 daily check list

Suzhou Jiajun Auto-Well Industrial Automation Co.,Ltd		Brand :Smart Wasp Model: X300			
Department	year	daily maintaince check record			
Equipment no.	month	measures	status	examiner/date	Confirmor/date
No.	Check Item				
1	Overall structure without looseness, motor without loose				
2	Indicator is normal, the PLC has signal input, sensors positioning sensor is normal				
3	The line doesn't fall off not loosely, the button is normal, the button and the movement conform to the inspection				
4	whether The motor is normal				
5	Equipment without a abnormal voice and smell				
6	whether Electromagnet obstruct device normal bounce				
7	whether cutting film system working smoothly				
8	Top Pressure plate screw weather tight.,up and down limited switch Weather works fine .				
No.	Breakdown contents	Maintenance countermeasures	Maintenance people	date	